

SNYDER

Equipment, Inc.

Storing, Rolling, Lifting since 1947



PRODUCT INFORMATION

OMNI GRAVITY CONVEYORS

2946 Larimer St. Denver, CO 80205
303-295-1100 / 800-373-7693
FAX 303-295-2464
Email info@snyderequipment.com
www.snyderequipment.com

Gravity

Conveyors

Omni Metalcraft Corp



Gravity Skatewheel Conveyor	124
Gravity Skatewheel Curve Conveyor	126
Gravity Skatewheel Spur Conveyor	128
Ball Transfer Table	129
Gravity Roller Conveyor	130
Gravity Roller Curve Conveyor	131
Gravity Roller Conveyor	132
Gravity Rollers	139
Flow Rail	140
Pallet Rail	140
Conveyor Supports	141

Gravity Skatewheel Conveyor

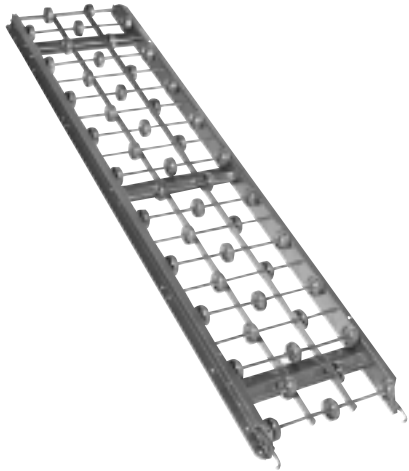

Gravity Skatewheel Conveyor is uniquely designed to convey lightweight packages or for use in operations requiring lightweight moveable sections.

- 6 Widths
- Steel or Aluminum Frames
- Wheels High or Low
- Axles on 1 1/2 in., 3 in. or 4 in. Centers

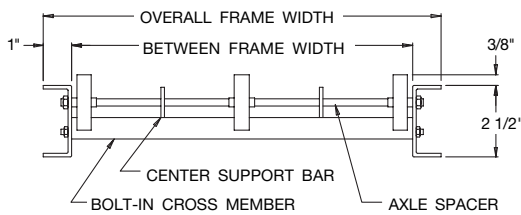

WHEELS HIGH

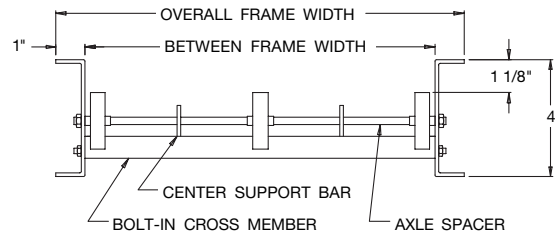

WHEELS LOW

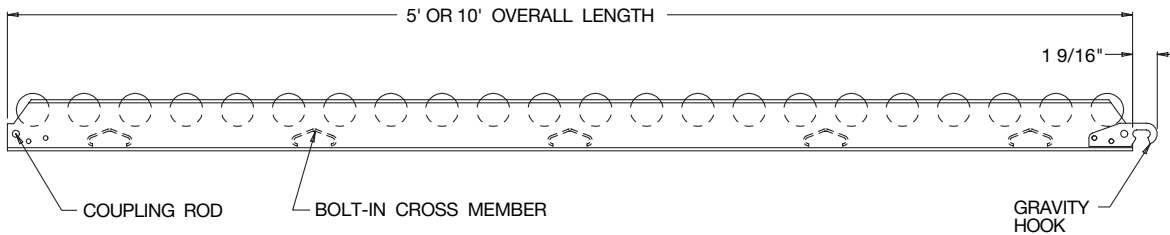

LOAD CAPACITY CHART			
Frame Material	Support Centers	Frame Capacity	Wheel Capacity
		Max. Uniformly Distributed Load	Max. Static Load Per Wheel
Steel	5'	1300	65
	10'	350	
Aluminum	5'	710	50
	10'	160	

Note: Frame capacities shown are for 2 1/2 in. deep frames only.

Standard Specifications:

Frame - 2 1/2 in. deep x 1 in. flange x 12 ga. galvanized steel or 1/8 in. aluminum channel with bolt-in cross members spaced every 2 ft. Also available - economy lite line with 14 ga. channel frames. 4 in. deep channel frames for rollers low.

Widths - 12 in., 15 in., 18 in., 21 in., 24 in. and 30 in. overall.

Couplings - Gravity hooks on one end - rod on opposite end. All couplings are bolted to frame. Bolt-in end couplers also available.

Lengths - 5 ft. and 10 ft. straight sections. Special lengths also available.

Wheels - 1 15/16 in. dia. - ball bearings run in hardened raceway with lifetime lubrication. Corrosion-resistant aluminum, zinc coated steel, black plastic or white plastic also available.

Axles - 1/4 in. dia. threaded one end with locknut. Spaced on 1 1/2 in., 3 in. or 4 in. centers. Spacers are zinc coated steel.

STEEL

12" OVERALL WIDTH					15" OVERALL WIDTH					18" OVERALL WIDTH				
MODEL NO.	WPF	WT. (LBS.)			MODEL NO.	WPF	WT. (LBS.)			MODEL NO.	WPF	WT. (LBS.)		
		10'	5'				10'	5'				10'	5'	
WSHS1.5 - 12 - 12	12	86	44		WSHS1.5 - 15 - 12	12	93	48		WSHS1.5 - 18 - 24	24	121	62	
WSHS1.5 - 12 - 16	16	92	47		WSHS1.5 - 15 - 16	16	100	51		WSHS1.5 - 18 - 28	28	128	65	
WSHS1.5 - 12 - 20	20	99	50		WSHS1.5 - 15 - 20	20	107	54		WSHS1.5 - 18 - 32	32	134	68	
WSHS1.5 - 12 - 24	24	106	54		WSHS1.5 - 15 - 24	24	113	58		WSHS1.5 - 18 - 36	36	141	72	
WSHS1.5 - 12 - 32	32	120	61		WSHS1.5 - 15 - 32	32	127	65		WSHS1.5 - 18 - 40	40	148	75	

**1 1/2 IN.
AXLE
SPACING**

12" OVERALL WIDTH					15" OVERALL WIDTH					18" OVERALL WIDTH				
MODEL NO.	WPF	WT. (LBS.)			MODEL NO.	WPF	WT. (LBS.)			MODEL NO.	WPF	WT. (LBS.)		
		10'	5'				10'	5'				10'	5'	
WSHS3 - 12 - 6	6	66	34		WSHS3 - 15 - 6	6	70	36		WSHS3 - 18 - 12	12	85	44	
WSHS3 - 12 - 8	8	69	35		WSHS3 - 15 - 8	8	74	38		WSHS3 - 18 - 14	14	89	46	
WSHS3 - 12 - 10	10	72	37		WSHS3 - 15 - 10	10	77	40		WSHS3 - 18 - 16	16	92	47	
WSHS3 - 12 - 12	12	76	39		WSHS3 - 15 - 12	12	81	41		WSHS3 - 18 - 18	18	96	49	
WSHS3 - 12 - 16	16	83	42		WSHS3 - 15 - 16	16	87	45		WSHS3 - 18 - 20	20	99	51	

**3 IN.
AXLE
SPACING**

12" OVERALL WIDTH					15" OVERALL WIDTH					18" OVERALL WIDTH				
MODEL NO.	WPF	WT. (LBS.)			MODEL NO.	WPF	WT. (LBS.)			MODEL NO.	WPF	WT. (LBS.)		
		10'	5'				10'	5'				10'	5'	
WSHS4 - 12 - 4	4	60	31		WSHS4 - 15 - 4	4	64	33		WSHS4 - 18 - 9	9	77	40	
WSHS4 - 12 - 6	6	63	32		WSHS4 - 15 - 6	6	67	35		WSHS4 - 18 - 11	11	80	41	
WSHS4 - 12 - 8	8	67	34		WSHS4 - 15 - 8	8	71	36		WSHS4 - 18 - 12	12	82	42	
WSHS4 - 12 - 9	9	68	35		WSHS4 - 15 - 9	9	72	37		WSHS4 - 18 - 14	14	85	44	
WSHS4 - 12 - 12	12	73	38		WSHS4 - 15 - 12	12	77	40		WSHS4 - 18 - 15	15	87	45	

**4 IN.
AXLE
SPACING**

Note: Weights listed are for 2 1/2 in. deep frames. For 4 in. deep frames, add 6 lbs. to 5' long sections and 12 lbs. to 10' long sections.
 In Stock

ALUMINUM

12" OVERALL WIDTH					15" OVERALL WIDTH					18" OVERALL WIDTH				
MODEL NO.	WPF	WT. (LBS.)			MODEL NO.	WPF	WT. (LBS.)			MODEL NO.	WPF	WT. (LBS.)		
		10'	5'				10'	5'				10'	5'	
WAHS1.5 - 12 - 12	12	51	26		WAHS1.5 - 15 - 12	12	57	29		WAHS1.5 - 18 - 24	24	77	39	
WAHS1.5 - 12 - 16	16	55	28		WAHS1.5 - 15 - 16	16	62	31		WAHS1.5 - 18 - 28	28	82	42	
WAHS1.5 - 12 - 20	20	60	30		WAHS1.5 - 15 - 20	20	66	34		WAHS1.5 - 18 - 32	32	87	44	
WAHS1.5 - 12 - 24	24	65	33		WAHS1.5 - 15 - 24	24	71	36		WAHS1.5 - 18 - 36	36	91	46	
WAHS1.5 - 12 - 32	32	74	38		WAHS1.5 - 15 - 32	32	81	41		WAHS1.5 - 18 - 40	40	96	49	

**1 1/2 IN.
AXLE
SPACING**

12" OVERALL WIDTH					15" OVERALL WIDTH					18" OVERALL WIDTH				
MODEL NO.	WPF	WT. (LBS.)			MODEL NO.	WPF	WT. (LBS.)			MODEL NO.	WPF	WT. (LBS.)		
		10'	5'				10'	5'				10'	5'	
WAHS3 - 12 - 6	6	34	17		WAHS3 - 15 - 6	6	37	19		WAHS3 - 18 - 12	12	48	25	
WAHS3 - 12 - 8	8	36	18		WAHS3 - 15 - 8	8	40	20		WAHS3 - 18 - 14	14	50	26	
WAHS3 - 12 - 10	10	38	20		WAHS3 - 15 - 10	10	42	22		WAHS3 - 18 - 16	16	53	27	
WAHS3 - 12 - 12	12	41	23		WAHS3 - 15 - 12	12	45	23		WAHS3 - 18 - 18	18	55	28	
WAHS3 - 12 - 16	16	46	23		WAHS3 - 15 - 16	16	49	25		WAHS3 - 18 - 20	20	58	29	

**3 IN.
AXLE
SPACING**

12" OVERALL WIDTH					15" OVERALL WIDTH					18" OVERALL WIDTH				
MODEL NO.	WPF	WT. (LBS.)			MODEL NO.	WPF	WT. (LBS.)			MODEL NO.	WPF	WT. (LBS.)		
		10'	5'				10'	5'				10'	5'	
WAHS4 - 12 - 4	4	29	15		WAHS4 - 15 - 4	4	32	16		WAHS4 - 18 - 9	9	41	21	
WAHS4 - 12 - 6	6	31	16		WAHS4 - 15 - 6	6	34	18		WAHS4 - 18 - 11	11	43	22	
WAHS4 - 12 - 8	8	34	17		WAHS4 - 15 - 8	8	37	19		WAHS4 - 18 - 12	12	44	23	
WAHS4 - 12 - 9	9	35	18		WAHS4 - 15 - 9	9	38	19		WAHS4 - 18 - 14	14	47	24	
WAHS4 - 12 - 12	12	38	20		WAHS4 - 15 - 12	12	41	21		WAHS4 - 18 - 15	15	48	25	

**4 IN.
AXLE
SPACING**

Note: Weights listed are for 2 1/2 in. deep frames. For 4 in. deep frames, add 2 1/2 lbs. to 5' long sections and 5 lbs. to 10' long sections.
 In Stock

Gravity Conveyors

Gravity Skatewheel Curve Conveyor

Skatewheel Curves are compatible with straight sections, providing flexibility to your conveyor line. Differential action of the wheels insure proper orientation of packages.



■ 6 Widths

■ 45° and 90° Curves

■ Steel or Aluminum Frames

■ Gravity Hooks and Rods on Both Ends

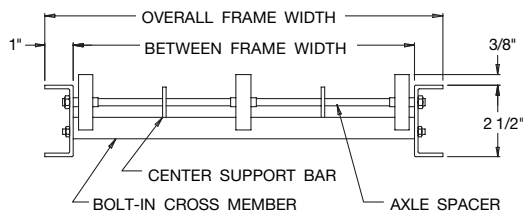

WHEELS HIGH

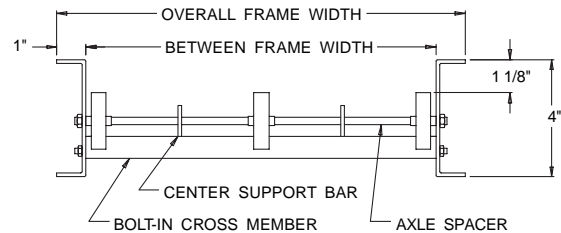

WHEELS LOW

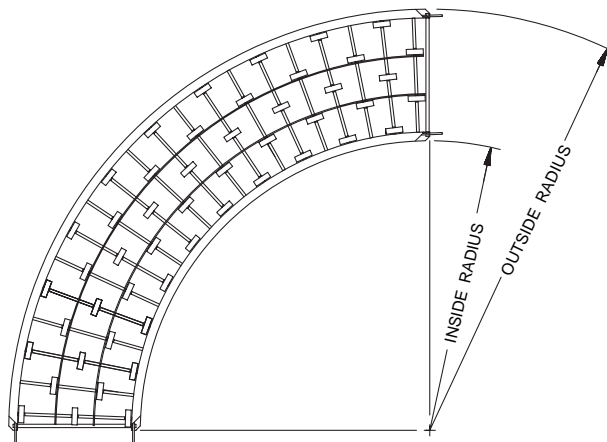

Overall Width	Inside Radius	Outside Radius
12"	36"	48"
15"	33"	48"
18"	30"	48"
21"	39"	60"
24"	36"	60"
30"	30"	60"

Standard Specifications:

Frame - 2 1/2 in. deep x 1 in. flange x 12 ga. galvanized steel or 1/8 in. aluminum channel with bolt-in cross members. 4 in. deep channel frames for wheels low.

Widths - 12 in., 15 in., 18 in., 21 in., 24 in. or 30 in. overall.

Curves - 45° and 90°; 48 in. outside radius - 12 in., 15 in. and 18 in. widths; 60 in. outside radius - 21 in., 24 in. and 30 in. widths.

Couplings - Gravity hooks and rods on both ends of curve. Bolt-in end couplers also available.

Wheels - 1 15/16 in. dia. - ball bearings run in hardened raceway with lifetime lubrication. Corrosion-resistant aluminum, zinc coated steel, black plastic or white plastic also available.

Axles - 1/4 in. dia. threaded one end with locknut. Spaced on 1 1/2 in. or 3 in. equivalent spacing. Spacers are zinc coated steel.

Capacity - Same "Per Foot" capacity as straight sections.

STEEL

12" OVERALL WIDTH				15" OVERALL WIDTH				18" OVERALL WIDTH			
MODEL NO.	WPF (EQUIV)	WT. (LBS.)		MODEL NO.	WPF (EQUIV)	WT. (LBS.)		MODEL NO.	WPF (EQUIV)	WT. (LBS.)	
		90°	45°			90°	45°			90°	45°
WSHC1.5 - 12 - 12	12	48	24	WSHC1.5 - 15 - 12	12	52	25	WSHC1.5 - 18 - 24	24	66	32
WSHC1.5 - 12 - 16	16	52	25	WSHC1.5 - 15 - 16	16	55	27	WSHC1.5 - 18 - 28	28	70	34
WSHC1.5 - 12 - 20	20	55	27	WSHC1.5 - 15 - 20	20	59	29	WSHC1.5 - 18 - 32	32	74	36
WSHC1.5 - 12 - 24	24	59	29	WSHC1.5 - 15 - 24	24	62	31	WSHC1.5 - 18 - 36	36	77	37
WSHC1.5 - 12 - 32	32	66	32	WSHC1.5 - 15 - 32	32	70	34	WSHC1.5 - 18 - 40	40	81	39

21" OVERALL WIDTH				24" OVERALL WIDTH				30" OVERALL WIDTH			
MODEL NO.	WPF (EQUIV)	WT. (LBS.)		MODEL NO.	WPF (EQUIV)	WT. (LBS.)		MODEL NO.	WPF (EQUIV)	WT. (LBS.)	
		90°	45°			90°	45°			90°	45°
WSHC1.5 - 21 - 24	24	88	46	WSHC1.5 - 24 - 32	32	105	54	WSHC1.5-30-32	32	117	60
WSHC1.5 - 21 - 28	28	93	48	WSHC1.5 - 24 - 36	36	109	56	WSHC1.5-30-40	40	126	65
WSHC1.5 - 21 - 32	32	96	50	WSHC1.5 - 24 - 40	40	113	58	WSHC1.5-30-48	48	134	69
WSHC1.5 - 21 - 40	40	106	55	WSHC1.5 - 24 - 48	48	122	63	WSHC1.5-30-56	56	143	74
WSHC1.5 - 21 - 48	48	115	59	WSHC1.5 - 24 - 56	56	131	67	WSHC1.5-30-72	72	161	83

1 1/2 IN. EQUIV. AXLE SPACING

12" OVERALL WIDTH				15" OVERALL WIDTH				18" OVERALL WIDTH			
MODEL NO.	WPF (EQUIV)	WT. (LBS.)		MODEL NO.	WPF (EQUIV)	WT. (LBS.)		MODEL NO.	WPF (EQUIV)	WT. (LBS.)	
		90°	45°			90°	45°			90°	45°
WSHC3 - 12 - 6	6	38	19	WSHC3 - 15 - 6	6	40	20	WSHC3 - 18 - 12	12	48	23
WSHC3 - 12 - 8	8	39	19	WSHC3 - 15 - 8	8	41	21	WSHC3 - 18 - 14	14	50	24
WSHC3 - 12 - 10	10	41	20	WSHC3 - 15 - 10	10	43	22	WSHC3 - 18 - 16	16	51	25
WSHC3 - 12 - 12	12	43	21	WSHC3 - 15 - 12	12	45	23	WSHC3 - 18 - 18	18	53	26
WSHC3 - 12 - 16	16	47	23	WSHC3 - 15 - 16	16	49	24	WSHC3 - 18 - 20	20	55	27

21" OVERALL WIDTH				24" OVERALL WIDTH				30" OVERALL WIDTH			
MODEL NO.	WPF (EQUIV)	WT. (LBS.)		MODEL NO.	WPF (EQUIV)	WT. (LBS.)		MODEL NO.	WPF (EQUIV)	WT. (LBS.)	
		90°	45°			90°	45°			90°	45°
WSHC3 - 21 - 12	12	64	33	WSHC3 - 24 - 16	16	74	39	WSHC3 - 30 - 16	16	83	43
WSHC3 - 21 - 14	14	66	34	WSHC3 - 24 - 18	18	76	40	WSHC3 - 30 - 20	20	87	46
WSHC3 - 21 - 16	16	68	36	WSHC3 - 24 - 20	20	78	41	WSHC3 - 30 - 24	24	91	48
WSHC3 - 21 - 20	20	72	38	WSHC3 - 24 - 24	24	83	43	WSHC3 - 30 - 28	28	96	50
WSHC3 - 21 - 24	24	77	40	WSHC3 - 24 - 28	28	87	45	WSHC3 - 30 - 36	36	105	54

3 IN. EQUIV. AXLE SPACING

Note: Weights listed are for 2 1/2 in. deep frames. For 4 in. deep frames, add 3 lbs. to 45° sections and 6 lbs. to 90° sections.

In Stock

ALUMINUM

12" OVERALL WIDTH				15" OVERALL WIDTH				18" OVERALL WIDTH			
MODEL NO.	WPF (EQUIV)	WT. (LBS.)		MODEL NO.	WPF (EQUIV)	WT. (LBS.)		MODEL NO.	WPF (EQUIV)	WT. (LBS.)	
		90°	45°			90°	45°			90°	45°
WAHC1.5 - 12 - 12	12	28	14	WAHC1.5 - 15 - 12	12	31	15	WAHC1.5 - 18 - 24	24	42	20
WAHC1.5 - 12 - 16	16	30	15	WAHC1.5 - 15 - 16	16	34	16	WAHC1.5 - 18 - 28	28	44	22
WAHC1.5 - 12 - 20	20	33	16	WAHC1.5 - 15 - 20	20	36	18	WAHC1.5 - 18 - 32	32	47	23
WAHC1.5 - 12 - 24	24	35	17	WAHC1.5 - 15 - 24	24	39	19	WAHC1.5 - 18 - 36	36	49	24
WAHC1.5 - 12 - 32	32	40	19	WAHC1.5 - 15 - 32	32	44	21	WAHC1.5 - 18 - 40	40	52	25

21" OVERALL WIDTH				24" OVERALL WIDTH				30" OVERALL WIDTH			
MODEL NO.	WPF (EQUIV)	WT. (LBS.)		MODEL NO.	WPF (EQUIV)	WT. (LBS.)		MODEL NO.	WPF (EQUIV)	WT. (LBS.)	
		90°	45°			90°	45°			90°	45°
WAHC1.5 - 21 - 24	24	57	29	WAHC1.5 - 24 - 32	32	68	35	WAHC1.5-30-32	32	77	39
WAHC1.5 - 21 - 28	28	60	31	WAHC1.5 - 24 - 36	36	71	36	WAHC1.5-30-40	40	83	42
WAHC1.5 - 21 - 32	32	62	32	WAHC1.5 - 24 - 40	40	74	38	WAHC1.5-30-48	48	89	46
WAHC1.5 - 21 - 40	40	69	35	WAHC1.5 - 24 - 48	48	80	41	WAHC1.5-30-56	56	95	49
WAHC1.5 - 21 - 48	48	75	38	WAHC1.5 - 24 - 56	56	86	44	WAHC1.5-30-72	72	108	55

1 1/2 IN. EQUIV. AXLE SPACING

12" OVERALL WIDTH				15" OVERALL WIDTH				18" OVERALL WIDTH			
MODEL NO.	WPF (EQUIV)	WT. (LBS.)		MODEL NO.	WPF (EQUIV)	WT. (LBS.)		MODEL NO.	WPF (EQUIV)	WT. (LBS.)	
		90°	45°			90°	45°			90°	45°
WAHC3 - 12 - 6	6	19	9	WAHC3 - 15 - 6	6	21	10	WAHC3 - 18 - 12	12	27	13
WAHC3 - 12 - 8	8	20	10	WAHC3 - 15 - 8	8	22	11	WAHC3 - 18 - 14	14	28	14
WAHC3 - 12 - 10	10	22	11	WAHC3 - 15 - 10	10	23	12	WAHC3 - 18 - 16	16	29	14
WAHC3 - 12 - 12	12	23	11	WAHC3 - 15 - 12	12	25	12	WAHC3 - 18 - 18	18	30	15
WAHC3 - 12 - 16	16	25	12	WAHC3 - 15 - 16	16	27	13	WAHC3 - 18 - 20	20	32	15

21" OVERALL WIDTH				24" OVERALL WIDTH				30" OVERALL WIDTH			
MODEL NO.	WPF (EQUIV)	WT. (LBS.)		MODEL NO.	WPF (EQUIV)	WT. (LBS.)		MODEL NO.	WPF (EQUIV)	WT. (LBS.)	
		90°	45°			90°	45°			90°	45°
WAHC3 - 21 - 12	12	36	19	WAHC3 - 24 - 16	16	46	24	WAHC3 - 30 - 16	16	48	25
WAHC3 - 21 - 14	14	37	20	WAHC3 - 24 - 18	18	48	25	WAHC3 - 30 - 20	20	51	27
WAHC3 - 21 - 16	16	39	21	WAHC3 - 24 - 20	20	49	26	WAHC3 - 30 - 24	24	54	28
WAHC3 - 21 - 20	20	42	22	WAHC3 - 24 - 24	24	53	27	WAHC3 - 30 - 28	28	57	30
WAHC3 - 21 - 24	24	45	23	WAHC3 - 24 - 28	28	56	29	WAHC3 - 30 - 36	36	64	33

3 IN. EQUIV. AXLE SPACING

Note: Weights listed are for 2 1/2 in. deep frames. For 4 in. deep frames, add 1 lb. to 45° sections and 2 lbs. to 90° sections.

In Stock

Gravity Skatewheel Spur Conveyor

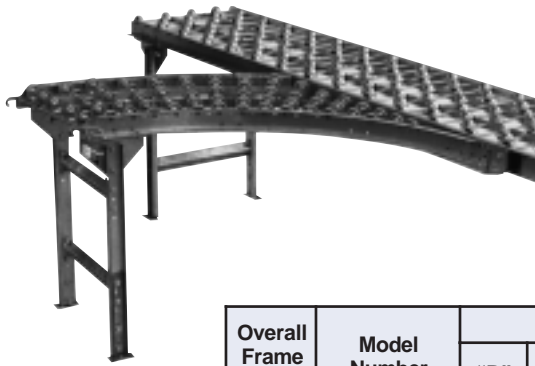

Skatewheel Spurs are used to transport products from one conveying line onto another. They are suitable for merging or diverging applications.

Overall Frame Width	Model Number	45° Spur				Model Number	90° Spur			
		"B"	"A" Weights (Lbs.)				"B"	"R"	"A"	Weight Lbs.
2'	3'		5'							
12"	WSHR3-12-"A"-45	20 3/4"	31	39	56	WSHR3-12-0-90	34 13/16"	36"	37 1/8"	67
15"	WSHR3-15-"A"-45	25"	34	43	62	WSHR3-15-0-90	38 1/16"	33"	34 1/8"	72
18"	WSHR3-18-"A"-45	29 1/4"	38	47	66	WSHR3-18-0-90	40 3/4"	30"	31 1/8"	77
21"	WSHR3-21-"A"-45	33 1/2"	41	52	80	WSHR3-21-0-90	49"	39"	40 1/8"	92
24"	WSHR3-24-"A"-45	37 3/4"	44	57	83	WSHR3-24-0-90	51 3/8"	36"	37 1/8"	107
30"	WSHR3-30-"A"-45	46 3/16"	50	67	99	WSHR3-30-0-90	55 1/2"	30"	31 1/8"	136

Note: Model numbers in the above chart are for right hand spurs. Replace "R" with "L" for left hand spur.

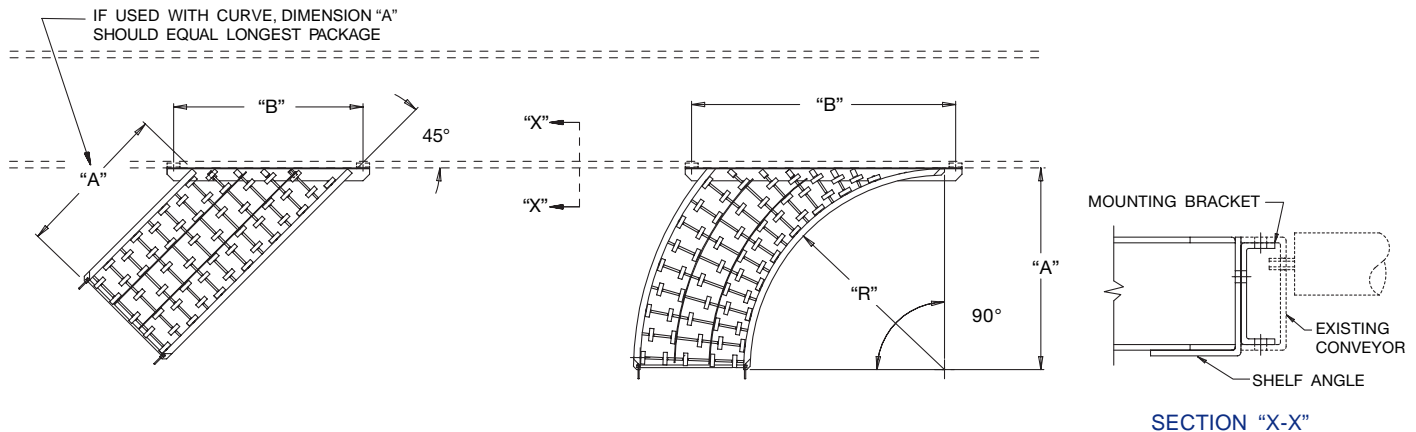
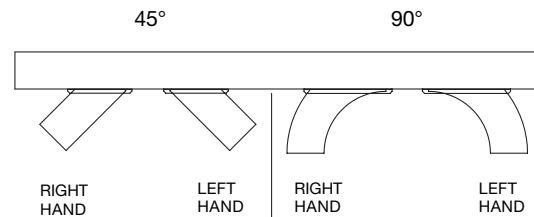
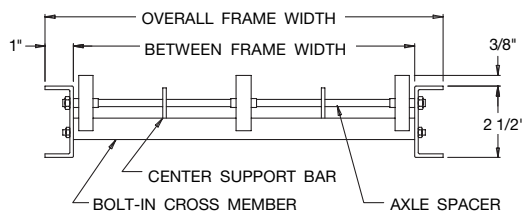

Standard Specifications:

Frame - 2 1/2 in. deep x 1 in. flange x 12 ga. galvanized steel channel with bolt-in cross members. Aluminum frames also available.

Widths - 12 in., 15 in., 18 in., 21 in., 24 in. and 30 in. overall.

Spur Angles - 45° and 90°, right or left hand.

Couplings - Gravity hooks and rods on one end. Spur shelf angle on opposite end. Bolt-in end couplers also available.

Wheels - 1 15/16 in. dia. - ball bearings run in hardened raceway with lifetime lubrication. Corrosion-resistant aluminum, zinc coated steel, black plastic or white plastic also available.

Axles - 1/4 in. dia. threaded one end with locknut. Spaced on 3 in. equivalent spacing. Spacers are zinc coated steel.

Capacity - Same "Per Foot" capacity as straight sections.

Ball Transfer Table

Ball Transfer Tables are used where products are required to manually rotate or move in any direction. They are compatible with 1 3/8 in. dia. and 1.9 in. dia. standard Gravity Roller Conveyor and Skatewheel Conveyor.

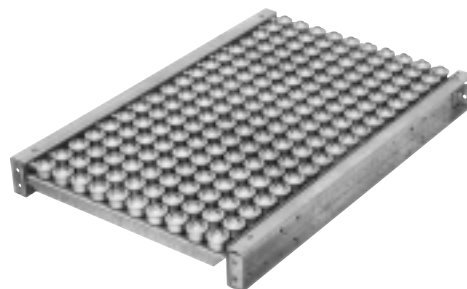

LOAD CAPACITY CHART		
Support Centers	Frame Capacity	Ball Capacity*
	Max. Uniformly Distributed Load	Max. Load Per Ball
5'	1300	50
10'	1200	

*Note: Maximum product weight should not exceed 150 lbs. as product may only rest on 3 ball transfers at one time.

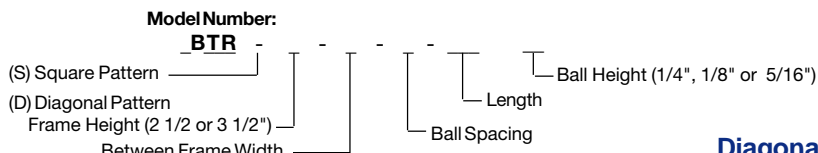

Cross Section for a 2 1/2 in. Deep Frame

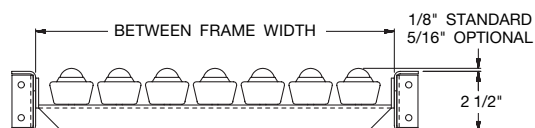

Cross Section for a 3 1/2 in. Deep Frame

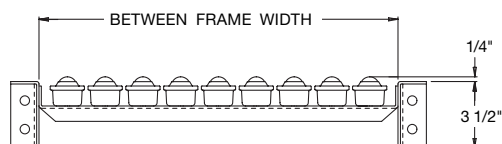

2 1/2 IN. DEEP FRAMES (WEIGHT PER FOOT)					
Between Frame Width	2" Cntrs. Square	3" Cntrs. Diagonal	4" Cntrs. Square	6" Cntrs. Square	6" Cntrs. Diagonal
10	28	22	----	----	----
13	26	23	21	18	18
16	33	25	22	19	19
10	38	28	24	21	21
13	43	31	27	23	23
16	53	38	32	28	28

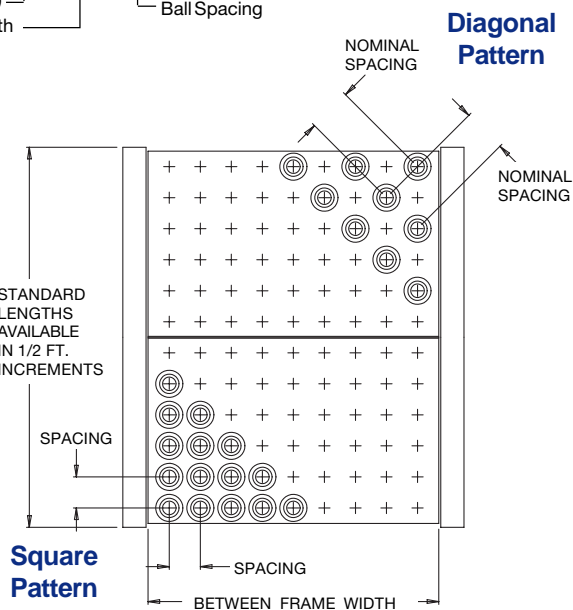

3 1/2 IN. DEEP FRAMES (WEIGHT PER FOOT)					
Between Frame Width	2" Cntrs. Square	3" Cntrs. Diagonal	4" Cntrs. Square	6" Cntrs. Square	6" Cntrs. Diagonal
13	28	22	20	----	----
14	29	23	21	----	----
15	32	24	21	18	18
16	33	25	22	19	19
17	35	26	23	20	20
18	36	27	24	21	21
16	38	28	24	21	21
20	39	29	25	22	22
21	42	30	26	22	22
22	43	31	27	23	23
23	45	33	28	24	24
24	46	34	29	25	25
25	49	35	30	26	26
26	50	36	31	27	27
27	52	37	31	27	27
28	53	38	32	28	28
29	55	39	33	29	29
30	56	40	34	30	30
31	59	42	35	30	30
32	60	43	36	31	31
33	62	44	37	31	31
34	63	45	38	32	32
35	66	46	38	33	33
36	67	47	39	34	34
37	69	49	40	34	34
38	70	50	41	35	35
39	72	51	41	35	35

Standard Specifications:

Frame - 3 1/2 in. deep x 1 1/2 in. flange x 10 ga. galvanized steel channel with bolt-in 10 ga. pans. Also available with 2 1/2 in. deep x 1 in. flange x 12 ga. galvanized steel channel frame.

Between Frame Widths - 13 through 39 in one inch increments for 3 1/2 in. deep frames. 10 in., 13 in., 16 in., 19 in., 22 in. and 28 in. for 2 1/2 in. deep frames.

Lengths - 2 ft. through 10 ft. in 1/2 foot increments.

End Couplers - Bolt-on type each end.

Ball Transfers - 1 in dia. ball transfers.

Spacings - Square spacings of 2 in., 4 in. and 6 in. Nominal diagonal spacings of 3 in. and 6 in.

Gravity Roller Conveyor

1 3/8 in. dia. x 18 ga. Rollers



1 3/8 in. dia. Gravity Roller Conveyor is ideal for carrying lightweight packages or in operations requiring lightweight moveable sections.

- 6 Widths
- 8 Roller Spacings
- Steel or Aluminum Frames
- Rollers Set High or Low

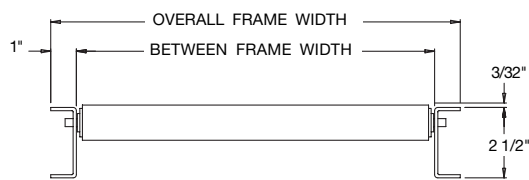

ROLLERS HIGH

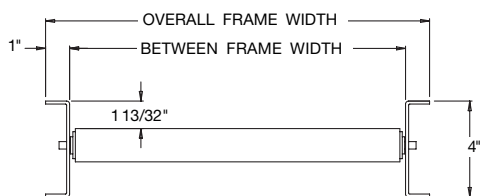

ROLLERS LOW

STEEL											
12" OVERALL WIDTH			15" OVERALL WIDTH			18" OVERALL WIDTH					
MODEL NO.	ROLLER CENTERS	WT. (LBS.)		MODEL NO.	ROLLER CENTERS	WT. (LBS.)		MODEL NO.	ROLLER CENTERS	WT. (LBS.)	
		10'	5'			10'	5'			10'	5'
RSHS1.4-12-1.5	1.5	107	54	RSHS1.4-15-1.5	1.5	127	64	RSHS1.4-18-1.5	1.5	146	74
RSHS1.4-12-3	3	74	38	RSHS1.4-15-3	3	85	44	RSHS1.4-18-3	3	96	49
RSHS1.4-12-4	4	65	34	RSHS1.4-15-4	4	74	38	RSHS1.4-18-4	4	83	43
RSHS1.4-12-4.5	4.5	63	33	RSHS1.4-15-4.5	4.5	72	37	RSHS1.4-18-4.5	4.5	80	41
RSHS1.4-12-6	6	57	30	RSHS1.4-15-6	6	64	34	RSHS1.4-18-6	6	71	38
RSHS1.4-12-8	8	53	28	RSHS1.4-15-8	8	59	31	RSHS1.4-18-8	8	65	34
RSHS1.4-12-9	9	51	27	RSHS1.4-15-9	9	57	30	RSHS1.4-18-9	9	62	33
RSHS1.4-12-12	12	49	25	RSHS1.4-15-12	12	54	28	RSHS1.4-18-12	12	58	30
21" OVERALL WIDTH			24" OVERALL WIDTH			30" OVERALL WIDTH					
MODEL NO.	ROLLER CENTERS	WT. (LBS.)		MODEL NO.	ROLLER CENTERS	WT. (LBS.)		MODEL NO.	ROLLER CENTERS	WT. (LBS.)	
		10'	5'			10'	5'			10'	5'
RSHS1.4-21-1.5	1.5	165	84	RSHS1.4-24-1.5	1.5	184	93	RSHS1.4-30-1.5	1.5	223	113
RSHS1.4-21-3	3	106	55	RSHS1.4-24-3	3	117	61	RSHS1.4-30-3	3	139	72
RSHS1.4-21-4	4	91	48	RSHS1.4-24-4	4	100	52	RSHS1.4-30-4	4	118	61
RSHS1.4-21-4.5	4.5	89	46	RSHS1.4-24-4.5	4.5	97	50	RSHS1.4-30-4.5	4.5	114	59
RSHS1.4-21-6	6	78	41	RSHS1.4-24-6	6	85	45	RSHS1.4-30-6	6	98	53
RSHS1.4-21-8	8	70	37	RSHS1.4-24-8	8	76	40	RSHS1.4-30-8	8	88	46
RSHS1.4-21-9	9	67	35	RSHS1.4-24-9	9	73	38	RSHS1.4-30-9	9	83	44
RSHS1.4-21-12	12	63	32	RSHS1.4-24-12	12	67	35	RSHS1.4-30-12	12	77	40

Note: Weights listed are for 2 1/2 in. deep frames. For 4 in. deep frames, add 6 lbs. to 5 ft. sections; 12 lbs. to 10 ft. sections.

☐ In Stock

ALUMINUM											
12" OVERALL WIDTH			15" OVERALL WIDTH			18" OVERALL WIDTH					
MODEL NO.	ROLLER CENTERS	WT. (LBS.)		MODEL NO.	ROLLER CENTERS	WT. (LBS.)		MODEL NO.	ROLLER CENTERS	WT. (LBS.)	
		10'	5'			10'	5'			10'	5'
RAHS1.4-12-1.5	1.5	56	29	RAHS1.4-15-1.5	1.5	66	33	RAHS1.4-18-1.5	1.5	75	38
RAHS1.4-12-3	3	37	19	RAHS1.4-15-3	3	42	22	RAHS1.4-18-3	3	47	25
RAHS1.4-12-4	4	32	17	RAHS1.4-15-4	4	36	19	RAHS1.4-18-4	4	40	21
RAHS1.4-12-4.5	4.5	30	16	RAHS1.4-15-4.5	4.5	32	17	RAHS1.4-18-4.5	4.5	37	19
RAHS1.4-12-6	6	27	15	RAHS1.4-15-6	6	31	16	RAHS1.4-18-6	6	34	18
RAHS1.4-12-8	8	25	13	RAHS1.4-15-8	8	28	15	RAHS1.4-18-8	8	30	16
RAHS1.4-12-9	9	24	13	RAHS1.4-15-9	9	26	14	RAHS1.4-18-9	9	29	15
RAHS1.4-12-12	12	22	12	RAHS1.4-15-12	12	24	13	RAHS1.4-18-12	12	27	14
21" OVERALL WIDTH			24" OVERALL WIDTH			30" OVERALL WIDTH					
MODEL NO.	ROLLER CENTERS	WT. (LBS.)		MODEL NO.	ROLLER CENTERS	WT. (LBS.)		MODEL NO.	ROLLER CENTERS	WT. (LBS.)	
		10'	5'			10'	5'			10'	5'
RAHS1.4-21-1.5	1.5	84	43	RAHS1.4-24-1.5	1.5	93	47	RAHS1.4-30-1.5	1.5	112	57
RAHS1.4-21-3	3	53	27	RAHS1.4-24-3	3	58	30	RAHS1.4-30-3	3	68	36
RAHS1.4-21-4	4	44	23	RAHS1.4-24-4	4	49	26	RAHS1.4-30-4	4	57	30
RAHS1.4-21-4.5	4.5	41	21	RAHS1.4-24-4.5	4.5	45	23	RAHS1.4-30-4.5	4.5	52	27
RAHS1.4-21-6	6	37	20	RAHS1.4-24-6	6	41	22	RAHS1.4-30-6	6	47	26
RAHS1.4-21-8	8	33	18	RAHS1.4-24-8	8	36	19	RAHS1.4-30-8	8	42	22
RAHS1.4-21-9	9	32	17	RAHS1.4-24-9	9	34	18	RAHS1.4-30-9	9	39	21
RAHS1.4-21-12	12	29	15	RAHS1.4-24-12	12	31	17	RAHS1.4-30-12	12	36	19

Note: Weights listed are for 2 1/2 in. deep frames. For 4 in. deep frames, add 2 1/2 lbs. to 5 ft. sections; 5 lbs. to 10 ft. sections.

☐ In Stock

LOAD CAPACITY CHART			
Frame Material	Support Centers	Frame Capacity	Roller Capacity
		Max. Uniformly Distributed Load	Max. Static Load Per Roller
Steel	5'	1300	120
	10'	350	
Aluminum	5'	710	
	10'	160	

Note: Frame capacities shown are for 2 1/2 in. deep frames only.

Standard Specifications:

Frame - 2 1/2 in. deep by 1 in. flange x 12 ga. galvanized steel or 1/8 in. aluminum channel with bolt-in cross members, spaced every 2 ft. An economy lite line is available with 14 ga. channel frames. 4 in. deep channel frames for rollers low.

Widths - 12 in., 15 in., 18 in., 21 in., 24 in. and 30 in. overall.

Lengths - 5 ft. and 10 ft. straight sections. Special lengths available.

End Couplers - Gravity hooks on one end - rod on opposite end. All couplings are bolted to frame. Bolt-in end couplers also available.

Rollers - 1 3/8 in. dia. x 18 ga. galvanized or heat-treated aluminum tubing. Oiled ball bearings both ends.

Axles - 1/4 in. dia. spring retained axle spaced on 1 1/2 in., 3 in., 4 in., 4 1/2 in., 6 in., 8 in., 9 in. or 12 in. centers.

Gravity Roller Curve Conveyor

1 3/8 in. dia. x 18 ga. Rollers

1 3/8 in. dia. Gravity Roller Curves are compatible with straight sections, providing flexibility to your conveyor line. They are ideal for carrying lightweight packages.



- 6 Widths
- 45° and 90° Curves
- Steel or Aluminum Frames
- Gravity Hooks and Rods on Both Ends

STEEL

12" OVERALL WIDTH (36" Inside Radius)				15" OVERALL WIDTH (33" Inside Radius)				18" OVERALL WIDTH (30" Inside Radius)			
MODEL NO.	ROLLER CENTERS	WT. (LBS.)		MODEL NO.	ROLLER CENTERS	WT. (LBS.)		MODEL NO.	ROLLER CENTERS	WT. (LBS.)	
		90°	45°			90°	45°			90°	45°
RSHC1.4-12-1.5	1.5	58	29	RSHC1.4-15-1.5	1.5	--	--	RSHC1.4-18-1.5	1.5	--	--
RSHC1.4-12-3	3	42	22	RSHC1.4-15-3	3	47	24	RSHC1.4-18-3	3	49	27

21" OVERALL WIDTH (39" Inside Radius)				24" OVERALL WIDTH (36" Inside Radius)				30" OVERALL WIDTH (30" Inside Radius)			
MODEL NO.	ROLLER CENTERS	WT. (LBS.)		MODEL NO.	ROLLER CENTERS	WT. (LBS.)		MODEL NO.	ROLLER CENTERS	WT. (LBS.)	
		90°	45°			90°	45°			90°	45°
RSHC1.4-21-1.5	1.5	92	46	RSHC1.4-24-1.5	1.5	102	51	RSHC1.4-30-1.5	1.5	--	--
RSHC1.4-21-3	3	63	32	RSHC1.4-24-3	3	69	35	RSHC1.4-30-3	3	76	41

Note: Weights listed are for 2 1/2 in. deep frames. For 4 in. deep frames, add 2 1/2 lbs. to 45° sections; 5 lbs. to 90° sections.

☐ In Stock

ALUMINUM

12" OVERALL WIDTH (36" Inside Radius)				15" OVERALL WIDTH (33" Inside Radius)				18" OVERALL WIDTH (30" Inside Radius)			
MODEL NO.	ROLLER CENTERS	WT. (LBS.)		MODEL NO.	ROLLER CENTERS	WT. (LBS.)		MODEL NO.	ROLLER CENTERS	WT. (LBS.)	
		90°	45°			90°	45°			90°	45°
RAHC1.4-12-1.5	1.5	31	16	RAHC1.4-15-1.5	1.5	--	--	RAHC1.4-18-1.5	1.5	--	--
RAHC1.4-12-3	3	21	11	RAHC1.4-15-3	3	24	13	RAHC1.4-18-3	3	27	14

21" OVERALL WIDTH (39" Inside Radius)				24" OVERALL WIDTH (36" Inside Radius)				30" OVERALL WIDTH (30" Inside Radius)			
MODEL NO.	ROLLER CENTERS	WT. (LBS.)		MODEL NO.	ROLLER CENTERS	WT. (LBS.)		MODEL NO.	ROLLER CENTERS	WT. (LBS.)	
		90°	45°			90°	45°			90°	45°
RAHC1.4-21-1.5	1.5	47	24	RAHC1.4-24-1.5	1.5	52	26	RAHC1.4-30-1.5	1.5	--	--
RAHC1.4-21-3	3	31	16	RAHC1.4-24-3	3	34	18	RAHC1.4-30-3	3	40	21

Note: Weights listed are for 2 1/2 in. deep frames. For 4 in. deep frames, add 2 1/2 lbs. to 45° sections; 5 lbs. to 90° sections.

☐ In Stock

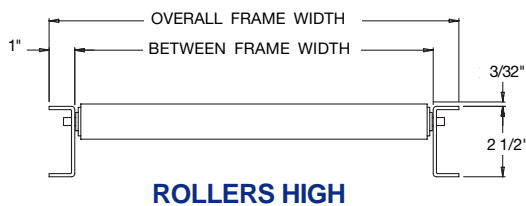
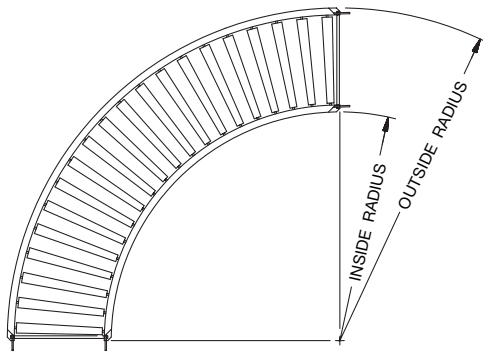

ROLLERS HIGH

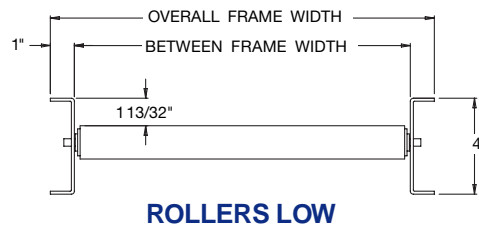

ROLLERS LOW

Frame - 2 1/2 in. deep x 1 in. flange x 12 ga. galvanized steel or 1/8 in. aluminum channel with bolt-in cross members. 4 in. deep channel frames for rollers low.

Widths - 12 in., 15 in., 18 in., 21 in., 24 in. and 30 in. overall.

Curves - 45° and 90°: 48 in. outside radius - 12 in., 15 in. and 18 in. widths; 60 in. outside radius - 21 in., 24 in. and 30 in. widths.

End Couplers - Gravity hooks and rods on both ends of curve. Bolt-in end couplers also available.

Rollers - 1 3/8 in. dia. x 18 ga. galvanized or heat-treated aluminum tubing. Oiled ball bearings both ends.

Axles - 1/4 in. dia. spring retained axle spaced on 1 1/2 in. or 3 in. equivalent spacing.

Capacity - Same "Per Foot" capacity as straight sections.

Gravity Roller Conveyor

1.9 in. dia. x 16 ga. Rollers



1.9 in. dia. Gravity Roller Conveyor is used in permanent installations. It provides an economical means of carrying lightweight to medium weight packages.

- 27 Between Frame Widths
- 8 Roller Centers
- Bolt-in Cross Members

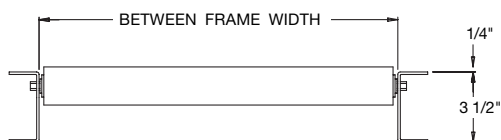

ROLLERS HIGH

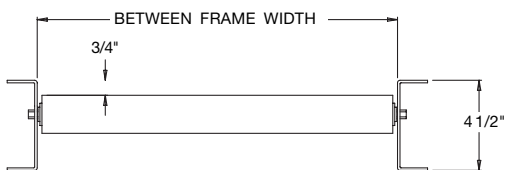

**ROLLERS LOW
(Optional)**

LOAD CAPACITY CHART		
Support Centers	Frame Capacity	Roller Capacity
	Max. Uniformly Distributed Load	Max. Load Per Roller
5'	3300	260
10'	1200	

Note: Frame capacities shown are for 3 1/2 in. deep frames only.

Between Frame Width	Model No. 1.9 x 16 ga. Rollers	Roller Centers (inches)	Weights (Lbs.)	
			5'	10'
13	GPHS-1.9x16-13-2	2	103	205
	GPHS-1.9x16-13-3	3	80	159
	GPHS-1.9x16-13-4.5	4.5	64	129
	GPHS-1.9x16-13-6	6	57	113
14	GPHS-1.9x16-14-2	2	109	217
	GPHS-1.9x16-14-3	3	84	167
	GPHS-1.9x16-14-4.5	4.5	67	134
	GPHS-1.9x16-14-6	6	59	117
15	GPHS-1.9x16-15-2	2	112	223
	GPHS-1.9x16-15-3	3	86	171
	GPHS-1.9x16-15-4.5	4.5	68	138
	GPHS-1.9x16-15-6	6	60	119
16	GPHS-1.9x16-16-2	2	119	236
	GPHS-1.9x16-16-3	3	91	180
	GPHS-1.9x16-16-4.5	4.5	71	144
	GPHS-1.9x16-16-6	6	63	124
17	GPHS-1.9x16-17-2	2	125	248
	GPHS-1.9x16-17-3	3	95	188
	GPHS-1.9x16-17-4.5	4.5	74	149
	GPHS-1.9x16-17-6	6	65	128
18	GPHS-1.9x16-18-2	2	128	255
	GPHS-1.9x16-18-3	3	97	193
	GPHS-1.9x16-18-4.5	4.5	75	153
	GPHS-1.9x16-18-6	6	66	131
19	GPHS-1.9x16-19-2	2	134	267
	GPHS-1.9x16-19-3	3	101	201
	GPHS-1.9x16-19-4.5	4.5	78	158
	GPHS-1.9x16-19-6	6	68	135
20	GPHS-1.9x16-20-2	2	138	274
	GPHS-1.9x16-20-3	3	104	206
	GPHS-1.9x16-20-4.5	4.5	80	162
	GPHS-1.9x16-20-6	6	70	138
21	GPHS-1.9x16-21-2	2	144	286
	GPHS-1.9x16-21-3	3	108	214
	GPHS-1.9x16-21-4.5	4.5	82	167
	GPHS-1.9x16-21-6	6	72	142
22	GPHS-1.9x16-22-2	2	147	293
	GPHS-1.9x16-22-3	3	110	219
	GPHS-1.9x16-22-4.5	4.5	84	171
	GPHS-1.9x16-22-6	6	73	145
23	GPHS-1.9x16-23-2	2	153	305
	GPHS-1.9x16-23-3	3	114	227
	GPHS-1.9x16-23-4.5	4.5	87	177
	GPHS-1.9x16-23-6	6	75	149
24	GPHS-1.9x16-24-2	2	157	312
	GPHS-1.9x16-24-3	3	117	232
	GPHS-1.9x16-24-4.5	4.5	90	182
	GPHS-1.9x16-24-6	6	77	152
25	GPHS-1.9x16-25-2	2	163	324
	GPHS-1.9x16-25-3	3	121	240
	GPHS-1.9x16-25-4.5	4.5	91	186
	GPHS-1.9x16-25-6	6	79	156
26	GPHS-1.9x16-26-2	2	166	331
	GPHS-1.9x16-26-3	3	123	245
	GPHS-1.9x16-26-4.5	4.5	93	189
	GPHS-1.9x16-26-6	6	80	159

Note: Also available with 4 in., 8 in., 9 in., or 12 in. Roller Centers.
 In Stock

Between Frame Width	Model No. 1.9 x 16 ga. Rollers	Roller Centers (inches)	Weights (Lbs.)	
			5'	10'
27	GPHS-1.9x16-27-2	2	172	343
	GPHS-1.9x16-27-3	3	127	253
	GPHS-1.9x16-27-4.5	4.5	96	195
	GPHS-1.9x16-27-6	6	82	163
28	GPHS-1.9x16-28-2	2	178	356
	GPHS-1.9x16-28-3	3	131	262
	GPHS-1.9x16-28-4.5	4.5	99	201
	GPHS-1.9x16-28-6	6	84	168
29	GPHS-1.9x16-29-2	2	182	362
	GPHS-1.9x16-29-3	3	134	266
	GPHS-1.9x16-29-4.5	4.5	100	204
	GPHS-1.9x16-29-6	6	86	170
30	GPHS-1.9x16-30-2	2	188	375
	GPHS-1.9x16-30-3	3	138	275
	GPHS-1.9x16-30-4.5	4.5	102	207
	GPHS-1.9x16-30-6	6	88	175
31	GPHS-1.9x16-31-2	2	191	381
	GPHS-1.9x16-31-3	3	140	279
	GPHS-1.9x16-31-4.5	4.5	105	213
	GPHS-1.9x16-31-6	6	89	177
32	GPHS-1.9x16-32-2	2	194	388
	GPHS-1.9x16-32-3	3	142	284
	GPHS-1.9x16-32-4.5	4.5	106	216
	GPHS-1.9x16-32-6	6	90	180
33	GPHS-1.9x16-33-2	2	201	400
	GPHS-1.9x16-33-3	3	147	292
	GPHS-1.9x16-33-4.5	4.5	109	222
	GPHS-1.9x16-33-6	6	93	184
34	GPHS-1.9x16-34-2	2	207	413
	GPHS-1.9x16-34-3	3	151	301
	GPHS-1.9x16-34-4.5	4.5	110	225
	GPHS-1.9x16-34-6	6	95	189
35	GPHS-1.9x16-35-2	2	210	419
	GPHS-1.9x16-35-3	3	153	305
	GPHS-1.9x16-35-4.5	4.5	113	231
	GPHS-1.9x16-35-6	6	96	191
36	GPHS-1.9x16-36-2	2	213	426
	GPHS-1.9x16-36-3	3	155	310
	GPHS-1.9x16-36-4.5	4.5	115	234
	GPHS-1.9x16-36-6	6	97	194
37	GPHS-1.9x16-37-2	2	220	438
	GPHS-1.9x16-37-3	3	160	318
	GPHS-1.9x16-37-4.5	4.5	118	240
	GPHS-1.9x16-37-6	6	100	198
38	GPHS-1.9x16-38-2	2	223	445
	GPHS-1.9x16-38-3	3	162	323
	GPHS-1.9x16-38-4.5	4.5	119	243
	GPHS-1.9x16-38-6	6	101	201
39	GPHS-1.9x16-39-2	2	229	457
	GPHS-1.9x16-39-3	3	166	331
	GPHS-1.9x16-39-4.5	4.5	122	249
	GPHS-1.9x16-39-6	6	103	205

Standard Specifications:

Frame - 3 1/2 in. deep x 1 1/2 in. flange x 10 ga. galvanized steel channel with bolt-in cross members. An economy lite line is available with 12 ga. channel frames. 4 1/2 in. deep frames for rollers low.

Between Frame Widths - 13 through 39 in full one inch increments.

End Couplers - Bolt-on type for bolting sections together.

Lengths - 5 ft. and 10 ft. straight sections. Other lengths also available.

Rollers - 1.9 in. dia. x 16 ga. galvanized steel tubing. Grease-packed ball bearings both ends. Mild steel tubes also available.

Axles - 7/16 spring retained hex axle spaced on 2 in., 3 in., 4 in., 4 1/2 in., 6 in., 8 in., 9 in. or 12 in. centers.

Gravity Roller Conveyor

1.9 in. dia. x 13 ga. Rollers



1.9 in. dia. Gravity Roller Conveyor is used in permanent installations. It provides an economical means of carrying lightweight to medium weight packages.

- 27 Between Frame Widths
- 8 Roller Centers
- Bolt-in Cross Members

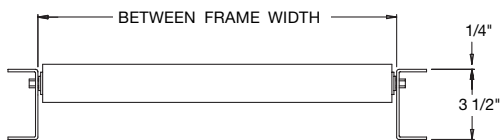

ROLLERS HIGH

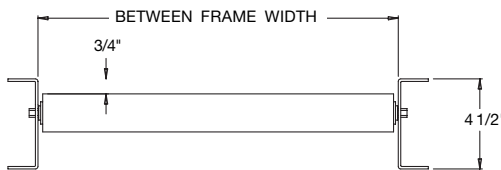

**ROLLERS LOW
(Optional)**

LOAD CAPACITY CHART		
Support Centers	Frame Capacity	Roller Capacity
	Max. Uniformly Distributed Load	Max. Load Per Roller
5'	3300	260
10'	1200	

Note: Frame capacities shown are for 3 1/2 in. deep frames only.

Between Frame Width	Model No. 1.9 x 13 ga. Rollers	Roller Centers (inches)	Weights (Lbs.)	
			5'	10'
13	GUHS-1.9x13-13-2	2	124	247
	GUHS-1.9x13-13-3	3	94	187
	GUHS-1.9x13-13-4.5	4.5	73	148
	GUHS-1.9x13-13-6	6	64	127
14	GUHS-1.9x13-14-2	2	130	259
	GUHS-1.9x13-14-3	3	98	195
	GUHS-1.9x13-14-4.5	4.5	76	153
	GUHS-1.9x13-14-6	6	66	131
15	GUHS-1.9x13-15-2	2	136	271
	GUHS-1.9x13-15-3	3	102	203
	GUHS-1.9x13-15-4.5	4.5	79	159
	GUHS-1.9x13-15-6	6	68	135
16	GUHS-1.9x13-16-2	2	143	284
	GUHS-1.9x13-16-3	3	107	212
	GUHS-1.9x13-16-4.5	4.5	81	165
	GUHS-1.9x13-16-6	6	71	140
17	GUHS-1.9x13-17-2	2	149	296
	GUHS-1.9x13-17-3	3	111	220
	GUHS-1.9x13-17-4.5	4.5	84	171
	GUHS-1.9x13-17-6	6	73	144
18	GUHS-1.9x13-18-2	2	155	309
	GUHS-1.9x13-18-3	3	115	229
	GUHS-1.9x13-18-4.5	4.5	87	177
	GUHS-1.9x13-18-6	6	75	149
19	GUHS-1.9x13-19-2	2	161	321
	GUHS-1.9x13-19-3	3	119	237
	GUHS-1.9x13-19-4.5	4.5	90	183
	GUHS-1.9x13-19-6	6	77	153
20	GUHS-1.9x13-20-2	2	168	334
	GUHS-1.9x13-20-3	3	124	246
	GUHS-1.9x13-20-4.5	4.5	93	189
	GUHS-1.9x13-20-6	6	80	158
21	GUHS-1.9x13-21-2	2	174	346
	GUHS-1.9x13-21-3	3	128	254
	GUHS-1.9x13-21-4.5	4.5	95	194
	GUHS-1.9x13-21-6	6	82	162
22	GUHS-1.9x13-22-2	2	180	359
	GUHS-1.9x13-22-3	3	132	263
	GUHS-1.9x13-22-4.5	4.5	98	200
	GUHS-1.9x13-22-6	6	84	167
23	GUHS-1.9x13-23-2	2	186	371
	GUHS-1.9x13-23-3	3	136	271
	GUHS-1.9x13-23-4.5	4.5	101	206
	GUHS-1.9x13-23-6	6	86	171
24	GUHS-1.9x13-24-2	2	193	384
	GUHS-1.9x13-24-3	3	141	280
	GUHS-1.9x13-24-4.5	4.5	104	212
	GUHS-1.9x13-24-6	6	89	176
25	GUHS-1.9x13-25-2	2	199	396
	GUHS-1.9x13-25-3	3	145	288
	GUHS-1.9x13-25-4.5	4.5	107	218
	GUHS-1.9x13-25-6	6	91	180
26	GUHS-1.9x13-26-2	2	205	409
	GUHS-1.9x13-26-3	3	149	297
	GUHS-1.9x13-26-4.5	4.5	110	224
	GUHS-1.9x13-26-6	6	93	185

Note: Also available with 4 in., 8 in., 9 in., or 12 in. Roller Centers.

Between Frame Width	Model No. 1.9 x 13 ga. Rollers	Roller Centers (inches)	Weights (Lbs.)	
			5'	10'
27	GUHS-1.9x13-27-2	2	211	421
	GUHS-1.9x13-27-3	3	153	305
	GUHS-1.9x13-27-4.5	4.5	113	230
	GUHS-1.9x13-27-6	6	95	189
28	GUHS-1.9x13-28-2	2	217	434
	GUHS-1.9x13-28-3	3	157	314
	GUHS-1.9x13-28-4.5	4.5	115	236
	GUHS-1.9x13-28-6	6	97	194
29	GUHS-1.9x13-29-2	2	224	446
	GUHS-1.9x13-29-3	3	162	322
	GUHS-1.9x13-29-4.5	4.5	118	242
	GUHS-1.9x13-29-6	6	100	198
30	GUHS-1.9x13-30-2	2	230	459
	GUHS-1.9x13-30-3	3	166	331
	GUHS-1.9x13-30-4.5	4.5	121	247
	GUHS-1.9x13-30-6	6	102	203
31	GUHS-1.9x13-31-2	2	236	471
	GUHS-1.9x13-31-3	3	170	339
	GUHS-1.9x13-31-4.5	4.5	124	253
	GUHS-1.9x13-31-6	6	104	207
32	GUHS-1.9x13-32-2	2	242	484
	GUHS-1.9x13-32-3	3	174	348
	GUHS-1.9x13-32-4.5	4.5	127	259
	GUHS-1.9x13-32-6	6	106	212
33	GUHS-1.9x13-33-2	2	249	496
	GUHS-1.9x13-33-3	3	179	356
	GUHS-1.9x13-33-4.5	4.5	130	265
	GUHS-1.9x13-33-6	6	109	216
34	GUHS-1.9x13-34-2	2	252	503
	GUHS-1.9x13-34-3	3	181	361
	GUHS-1.9x13-34-4.5	4.5	131	268
	GUHS-1.9x13-34-6	6	110	219
35	GUHS-1.9x13-35-2	2	258	515
	GUHS-1.9x13-35-3	3	185	369
	GUHS-1.9x13-35-4.5	4.5	134	274
	GUHS-1.9x13-35-6	6	112	223
36	GUHS-1.9x13-36-2	2	267	534
	GUHS-1.9x13-36-3	3	191	382
	GUHS-1.9x13-36-4.5	4.5	138	283
	GUHS-1.9x13-36-6	6	115	230
37	GUHS-1.9x13-37-2	2	274	546
	GUHS-1.9x13-37-3	3	196	390
	GUHS-1.9x13-37-4.5	4.5	141	289
	GUHS-1.9x13-37-6	6	118	234
38	GUHS-1.9x13-38-2	2	280	559
	GUHS-1.9x13-38-3	3	200	399
	GUHS-1.9x13-38-4.5	4.5	144	295
	GUHS-1.9x13-38-6	6	120	239
39	GUHS-1.9x13-39-2	2	283	565
	GUHS-1.9x13-39-3	3	202	403
	GUHS-1.9x13-39-4.5	4.5	145	298
	GUHS-1.9x13-39-6	6	121	241

Gravity Conveyors

Standard Specifications:

Frame - 3 1/2 in. deep x 1 1/2 in. flange x 10 ga. galvanized steel channel with bolt-in cross members. Specify 4 1/2 in. deep frames for rollers low. An economy lite line is also available with 12 ga. channel frames.

Between Frame Widths - 13 through 39 in full one inch increments.

End Couplers - Bolt-on type for bolting sections together.

Lengths - 5 ft. and 10 ft. straight sections. Other lengths also available.

Rollers - 1.9 in. dia. (1 7/8 in. actual) x 13 ga. steel tubing. Oiled plain ball bearings both ends.

Gravity Roller Conveyor

1.9 in. dia. x .145 Wall Rollers



1.9 in. dia. Gravity Roller Conveyor is used in permanent installations. It provides an economical means of carrying lightweight to medium weight packages.

- 27 Between Frame Widths
- 8 Roller Centers
- Bolt-in Cross Members

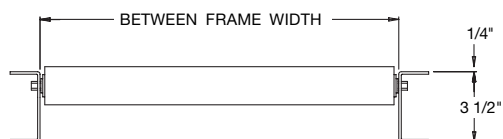

ROLLERS HIGH

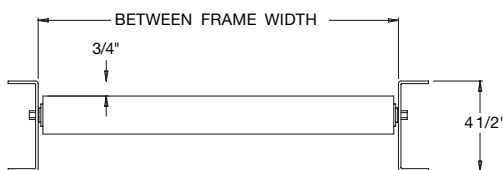

**ROLLERS LOW
(Optional)**

LOAD CAPACITY CHART		
Support Centers	Frame Capacity	Roller Capacity
	Max. Uniformly Distributed Load	Max. Load Per Roller
5'	3300	300
10'	1200	

Note: Frame capacities shown are for 3 1/2 in. deep frames only.

Between Frame Width	Model No. 1.9 x 9 ga. Rollers	Roller Centers (inches)	Weights (Lbs.)	
			5'	10'
13	GUHS-1.9x9-13-2	2	154	307
	GUHS-1.9x9-13-3	3	114	227
	GUHS-1.9x9-13-4.5	4.5	86	175
	GUHS-1.9x9-13-6	6	74	147
14	GUHS-1.9x9-14-2	2	160	319
	GUHS-1.9x9-14-3	3	118	235
	GUHS-1.9x9-14-4.5	4.5	89	180
	GUHS-1.9x9-14-6	6	76	151
15	GUHS-1.9x9-15-2	2	169	337
	GUHS-1.9x9-15-3	3	124	247
	GUHS-1.9x9-15-4.5	4.5	93	189
	GUHS-1.9x9-15-6	6	79	157
16	GUHS-1.9x9-16-2	2	179	356
	GUHS-1.9x9-16-3	3	131	260
	GUHS-1.9x9-16-4.5	4.5	97	198
	GUHS-1.9x9-16-6	6	83	164
17	GUHS-1.9x9-17-2	2	188	374
	GUHS-1.9x9-17-3	3	137	272
	GUHS-1.9x9-17-4.5	4.5	101	206
	GUHS-1.9x9-17-6	6	86	170
18	GUHS-1.9x9-18-2	2	206	411
	GUHS-1.9x9-18-3	3	149	297
	GUHS-1.9x9-18-4.5	4.5	109	223
	GUHS-1.9x9-18-6	6	92	183
19	GUHS-1.9x9-19-2	2	212	423
	GUHS-1.9x9-19-3	3	153	305
	GUHS-1.9x9-19-4.5	4.5	112	229
	GUHS-1.9x9-19-6	6	94	187
20	GUHS-1.9x9-20-2	2	216	430
	GUHS-1.9x9-20-3	3	156	310
	GUHS-1.9x9-20-4.5	4.5	114	232
	GUHS-1.9x9-20-6	6	96	190
21	GUHS-1.9x9-21-2	2	222	442
	GUHS-1.9x9-21-3	3	160	318
	GUHS-1.9x9-21-4.5	4.5	116	237
	GUHS-1.9x9-21-6	6	98	194
22	GUHS-1.9x9-22-2	2	228	455
	GUHS-1.9x9-22-3	3	164	327
	GUHS-1.9x9-22-4.5	4.5	119	244
	GUHS-1.9x9-22-6	6	100	199
23	GUHS-1.9x9-23-2	2	237	473
	GUHS-1.9x9-23-3	3	170	339
	GUHS-1.9x9-23-4.5	4.5	123	252
	GUHS-1.9x9-23-6	6	103	205
24	GUHS-1.9x9-24-2	2	247	486
	GUHS-1.9x9-24-3	3	175	348
	GUHS-1.9x9-24-4.5	4.5	128	261
	GUHS-1.9x9-24-6	6	106	210
25	GUHS-1.9x9-25-2	2	253	504
	GUHS-1.9x9-25-3	3	181	360
	GUHS-1.9x9-25-4.5	4.5	130	267
	GUHS-1.9x9-25-6	6	109	216
26	GUHS-1.9x9-26-2	2	262	523
	GUHS-1.9x9-26-3	3	187	373
	GUHS-1.9x9-26-4.5	4.5	135	275
	GUHS-1.9x9-26-6	6	112	223

Note: Also available with 4 in., 8 in., 9 in., or 12 in. Roller Centers.

Between Frame Width	Model No. 1.9 x 9 ga. Rollers	Roller Centers (inches)	Weights (Lbs.)	
			5'	10'
27	GUHS-1.9x9-27-2	2	271	541
	GUHS-1.9x9-27-3	3	193	385
	GUHS-1.9x9-27-4.5	4.5	139	284
	GUHS-1.9x9-27-6	6	115	229
28	GUHS-1.9x9-28-2	2	277	554
	GUHS-1.9x9-28-3	3	197	394
	GUHS-1.9x9-28-4.5	4.5	141	290
	GUHS-1.9x9-28-6	6	117	234
29	GUHS-1.9x9-29-2	2	287	572
	GUHS-1.9x9-29-3	3	204	406
	GUHS-1.9x9-29-4.5	4.5	146	298
	GUHS-1.9x9-29-6	6	121	240
30	GUHS-1.9x9-30-2	2	296	591
	GUHS-1.9x9-30-3	3	210	419
	GUHS-1.9x9-30-4.5	4.5	150	307
	GUHS-1.9x9-30-6	6	124	247
31	GUHS-1.9x9-31-2	2	305	609
	GUHS-1.9x9-31-3	3	216	431
	GUHS-1.9x9-31-4.5	4.5	154	315
	GUHS-1.9x9-31-6	6	127	253
32	GUHS-1.9x9-32-2	2	314	628
	GUHS-1.9x9-32-3	3	222	444
	GUHS-1.9x9-32-4.5	4.5	158	324
	GUHS-1.9x9-32-6	6	130	260
33	GUHS-1.9x9-33-2	2	321	640
	GUHS-1.9x9-33-3	3	227	452
	GUHS-1.9x9-33-4.5	4.5	161	330
	GUHS-1.9x9-33-6	6	133	264
34	GUHS-1.9x9-34-2	2	330	659
	GUHS-1.9x9-34-3	3	233	465
	GUHS-1.9x9-34-4.5	4.5	165	338
	GUHS-1.9x9-34-6	6	136	271
35	GUHS-1.9x9-35-2	2	339	677
	GUHS-1.9x9-35-3	3	239	477
	GUHS-1.9x9-35-4.5	4.5	169	347
	GUHS-1.9x9-35-6	6	139	277
36	GUHS-1.9x9-36-2	2	354	708
	GUHS-1.9x9-36-3	3	249	498
	GUHS-1.9x9-36-4.5	4.5	176	361
	GUHS-1.9x9-36-6	6	144	288
37	GUHS-1.9x9-37-2	2	358	720
	GUHS-1.9x9-37-3	3	254	506
	GUHS-1.9x9-37-4.5	4.5	177	364
	GUHS-1.9x9-37-6	6	147	292
38	GUHS-1.9x9-38-2	2	364	727
	GUHS-1.9x9-38-3	3	256	511
	GUHS-1.9x9-38-4.5	4.5	180	370
	GUHS-1.9x9-38-6	6	148	295
39	GUHS-1.9x9-39-2	2	373	745
	GUHS-1.9x9-39-3	3	262	523
	GUHS-1.9x9-39-4.5	4.5	184	379
	GUHS-1.9x9-39-6	6	151	301

Standard Specifications:

Frame - 3 1/2 in. deep x 1 1/2 in. flange x 10 ga. galvanized steel channel with bolt-in cross members. An economy lite line is also available with 12 ga. channel frames. Specify 4 1/2 in. deep frames for rollers low.

Between Frame Widths - 13 through 39 in full one inch increments.

End Couplers - Bolt-on type for bolting sections together.

Lengths - 5 ft. and 10 ft. straight sections. Other lengths also available.

Rollers - 1.9 in. dia. x .145 wall steel tubing. Bearings are labyrinth shielded and oiled.

Axles - 7/16 spring retained hex axle spaced on 2 in., 3 in., 4 in., 4 1/2 in., 6 in., 8 in., 9 in. or 12 in. centers.

Gravity Roller Curve Conveyor

1.9 in. dia. Rollers

1.9 in. dia. Gravity Roller Curves are used in permanent installations to carry medium weight packages. They are compatible with straight sections providing flexibility to your conveyor line.

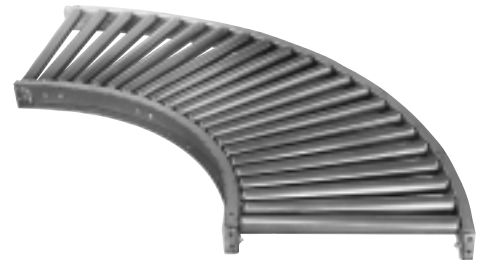

Between Frame Width	Rollers Per 90° Curve	Inside Radius	STRAIGHT ROLLER CURVE						TAPERED ROLLER CURVE					
			1.9 dia. x 16 ga. Rollers			1.9 dia. x 13 ga. Rollers			1.9 dia. x 9 ga. Rollers		2 1/2" to 1 11/16" x 14 ga. Tapered Rollers			
			Model Number	Weight (Lbs.)		Model Number	Weight (Lbs.)		Model Number	Weight (Lbs.)		Model Number	Weight (Lbs.)	
45°	90°	45°		90°	45°		90°	45°		90°				
13	22 Straight Rollers	32 1/2	GPHC1.9x16-13-3	52	92	GUHC1.9x13-13-3	60	105	GUHC1.9x9-13-3	71	129	GPHC1.9x16-13-3	66	110
14		32 1/2	GPHC1.9x16-14-3	55	96	GUHC1.9x13-14-3	62	110	GUHC1.9x9-14-3	73	136	GPHC1.9x16-14-3	69	115
15		32 1/2	GPHC1.9x16-15-3	57	100	GUHC1.9x13-15-3	65	115	GUHC1.9x9-15-3	77	143	GPHC1.9x16-15-3	73	121
16		32 1/2	GPHC1.9x16-16-3	59	104	GUHC1.9x13-16-3	68	120	GUHC1.9x9-16-3	81	149	GPHC1.9x16-16-3	76	126
17		32 1/2	GPHC1.9x16-17-3	62	109	GUHC1.9x13-17-3	70	126	GUHC1.9x9-17-3	85	156	GPHC1.9x16-17-3	79	132
18	20 Tapered Rollers	32 1/2	GPHC1.9x16-18-3	64	113	GUHC1.9x13-18-3	73	131	GUHC1.9x9-18-3	92	163	GPHC1.9x16-18-3	83	137
19		32 1/2	GPHC1.9x16-19-3	66	117	GUHC1.9x13-19-3	76	136	GUHC1.9x9-19-3	94	170	GPHC1.9x16-19-3	86	142
20		32 1/2	GPHC1.9x16-20-3	68	121	GUHC1.9x13-20-3	78	141	GUHC1.9x9-20-3	96	177	GPHC1.9x16-20-3	90	148
21		32 1/2	GPHC1.9x16-21-3	70	125	GUHC1.9x13-21-3	81	147	GUHC1.9x9-21-3	98	184	GPHC1.9x16-21-3	93	153
22		32 1/2	GPHC1.9x16-22-3	72	130	GUHC1.9x13-22-3	84	152	GUHC1.9x9-22-3	101	191	GPHC1.9x16-22-3	97	159
23	27 Tapered Rollers	32 1/2	GPHC1.9x16-23-3	74	134	GUHC1.9x13-23-3	86	157	GUHC1.9x9-23-3	105	198	GPHC1.9x16-23-3	100	164
24		32 1/2	GPHC1.9x16-24-3	76	138	GUHC1.9x13-24-3	89	162	GUHC1.9x9-24-3	109	204	GPHC1.9x16-24-3	103	169
25		32 1/2	GPHC1.9x16-25-3	78	142	GUHC1.9x13-25-3	91	167	GUHC1.9x9-25-3	111	211	GPHC1.9x16-25-3	107	175
26		32 1/2	GPHC1.9x16-26-3	80	146	GUHC1.9x13-26-3	94	173	GUHC1.9x9-26-3	115	218	GPHC1.9x16-26-3	110	180
27		32 1/2	GPHC1.9x16-27-3	82	151	GUHC1.9x13-27-3	97	178	GUHC1.9x9-27-3	119	225	GPHC1.9x16-27-3	114	186
28	36 Straight Rollers	48	GPHC1.9x16-28-3	117	232	GUHC1.9x13-28-3	140	278	GUHC1.9x9-28-3	176	358	GPHC1.9x16-28-3	137	286
29		48	GPHC1.9x16-29-3	118	239	GUHC1.9x13-29-3	144	286	GUHC1.9x9-29-3	182	369	GPHC1.9x16-29-3	141	294
30		48	GPHC1.9x16-30-3	123	245	GUHC1.9x13-30-3	148	294	GUHC1.9x9-30-3	188	380	GPHC1.9x16-30-3	145	302
31		48	GPHC1.9x16-31-3	125	251	GUHC1.9x13-31-3	152	302	GUHC1.9x9-31-3	194	391	GPHC1.9x16-31-3	149	311
32		48	GPHC1.9x16-32-3	127	258	GUHC1.9x13-32-3	156	310	GUHC1.9x9-32-3	199	401	GPHC1.9x16-32-3	153	319
33	48	GPHC1.9x16-33-3	131	264	GUHC1.9x13-33-3	160	318	GUHC1.9x9-33-3	203	412	GPHC1.9x16-33-3	169	327	
34	32 Tapered Rollers	48	GPHC1.9x16-34-3	135	270	GUHC1.9x13-34-3	162	326	GUHC1.9x9-34-3	209	423	GPHC1.9x16-34-3	174	335
35		48	GPHC1.9x16-35-3	138	276	GUHC1.9x13-35-3	166	334	GUHC1.9x9-35-3	215	433	GPHC1.9x16-35-3	179	343
36		48	GPHC1.9x16-36-3	140	283	GUHC1.9x13-36-3	172	342	GUHC1.9x9-36-3	224	444	GPHC1.9x16-36-3	183	351
37		48	GPHC1.9x16-37-3	144	289	GUHC1.9x13-37-3	176	350	GUHC1.9x9-37-3	227	455	GPHC1.9x16-37-3	187	360
38		48	GPHC1.9x16-38-3	146	295	GUHC1.9x13-38-3	180	358	GUHC1.9x9-38-3	231	465	GPHC1.9x16-38-3	196	368
39	48	GPHC1.9x16-39-3	150	302	GUHC1.9x13-39-3	183	366	GUHC1.9x9-39-3	237	476	GPHC1.9x16-39-3	205	376	

* For tapered rollers, add "T" to Model Number. Example: GUHC1.9 x 16-13-3-45T

☐ In Stock

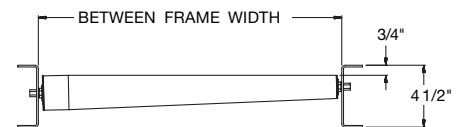
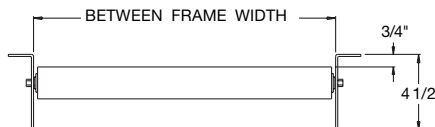
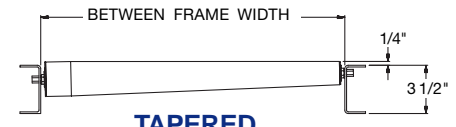
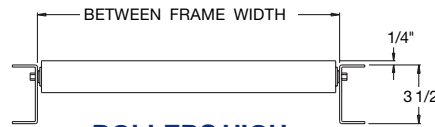
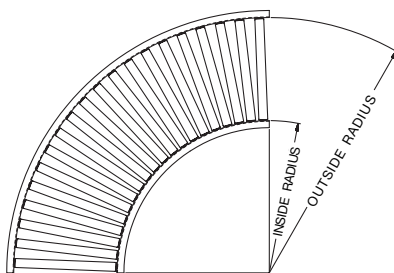

Standard Specifications:

Frame - 3 1/2 in. deep x 1 1/2 in. flange x 10 ga. galvanized steel channel with bolt-in cross members. Specify 4 1/2 in. deep frames for rollers low.

Between Frame Widths - 13 through 39 in full one inch increments.

Curves - 45° and 90° with 32 1/2 in. inside radius for widths up to 27 in. and 48 in. inside radius for 28 in. through 39 in. widths.

End Couplers - Bolt-on type each end.

Rollers - 1.9 in. dia. x 16 ga. galvanized steel or unplated tube with grease-packed ball bearings both ends. 1.9 in. dia. x 13 ga. and 1.9 in. dia. x 9 ga. steel tube also available with oiled ball bearings both ends. 2 1/2" to 1 11/16" tapered zinc plated rollers. Mild steel tapered rollers also available.

Axles - 7/16" spring retained hex axle spaced on 3 in. equivalent centers.

Capacity - Same "Per Foot" capacity as straight sections.

Gravity Roller Conveyor

2 1/2 in. dia. x 11 ga. Rollers

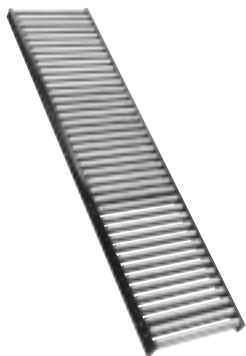

2 1/2 in. dia. Gravity Roller Conveyor is used in permanent installations. It provides an economical means of carrying medium to heavy weight packages.

- 27 Between Frame Widths
- 6 Roller Centers
- Painted Steel Frames
- Bolt-in Cross Members

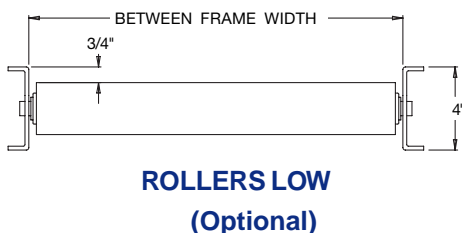
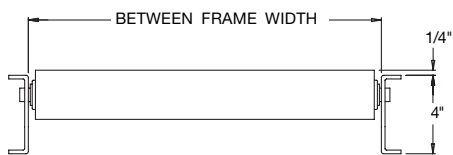

LOAD CAPACITY CHART		
Support Centers	Frame Capacity	Roller Capacity
	Max. Uniformly Distributed Load	Max. Load Per Roller
5'	5200	650
10'	2100	

Between Frame Width	Model No. 2.5 x 11 ga. Rollers	Roller Centers (inches)	Weights (Lbs.)	
			5'	10'
13	GUHS-2.5x11-13-3	3	167	333
	GUHS-2.5x11-13-4	4	137	273
	GUHS-2.5x11-13-6	6	113	219
	GUHS-2.5x11-13-8	8	95	189
14	GUHS-2.5x11-14-3	3	175	350
	GUHS-2.5x11-14-4	4	143	286
	GUHS-2.5x11-14-6	6	118	228
	GUHS-2.5x11-14-8	8	98	196
15	GUHS-2.5x11-15-3	3	182	363
	GUHS-2.5x11-15-4	4	148	296
	GUHS-2.5x11-15-6	6	121	235
	GUHS-2.5x11-15-8	8	101	202
16	GUHS-2.5x11-16-3	3	190	379
	GUHS-2.5x11-16-4	4	155	308
	GUHS-2.5x11-16-6	6	126	244
	GUHS-2.5x11-16-8	8	105	209
17	GUHS-2.5x11-17-3	3	198	396
	GUHS-2.5x11-17-4	4	161	321
	GUHS-2.5x11-17-6	6	131	254
	GUHS-2.5x11-17-8	8	108	216
18	GUHS-2.5x11-18-3	3	205	409
	GUHS-2.5x11-18-4	4	166	331
	GUHS-2.5x11-18-6	6	135	261
	GUHS-2.5x11-18-8	8	111	222
19	GUHS-2.5x11-19-3	3	213	426
	GUHS-2.5x11-19-4	4	172	344
	GUHS-2.5x11-19-6	6	139	270
	GUHS-2.5x11-19-8	8	115	229
20	GUHS-2.5x11-20-3	3	220	439
	GUHS-2.5x11-20-4	4	177	354
	GUHS-2.5x11-20-6	6	143	277
	GUHS-2.5x11-20-8	8	118	235
21	GUHS-2.5x11-21-3	3	228	456
	GUHS-2.5x11-21-4	4	184	367
	GUHS-2.5x11-21-6	6	148	286
	GUHS-2.5x11-21-8	8	121	242
22	GUHS-2.5x11-22-3	3	236	472
	GUHS-2.5x11-22-4	4	190	379
	GUHS-2.5x11-22-6	6	153	296
	GUHS-2.5x11-22-8	8	125	249
23	GUHS-2.5x11-23-3	3	245	489
	GUHS-2.5x11-23-4	4	196	392
	GUHS-2.5x11-23-6	6	158	305
	GUHS-2.5x11-23-8	8	129	256
24	GUHS-2.5x11-24-3	3	251	502
	GUHS-2.5x11-24-4	4	201	402
	GUHS-2.5x11-24-6	6	161	312
	GUHS-2.5x11-24-8	8	131	262
25	GUHS-2.5x11-25-3	3	260	519
	GUHS-2.5x11-25-4	4	208	415
	GUHS-2.5x11-25-6	6	166	321
	GUHS-2.5x11-25-8	8	135	269
26	GUHS-2.5x11-26-3	3	268	536
	GUHS-2.5x11-26-4	4	214	428
	GUHS-2.5x11-26-6	6	171	330
	GUHS-2.5x11-26-8	8	139	276

Note: Also available with 9 in. or 12 in. roller centers.
 In Stock

Between Frame Width	Model No. 2.5 x 11 ga. Rollers	Roller Centers (inches)	Weights (Lbs.)	
			5'	10'
27	GUHS-2.5x11-27-3	3	277	553
	GUHS-2.5x11-27-4	4	221	441
	GUHS-2.5x11-27-6	6	176	340
	GUHS-2.5x11-27-8	8	142	284
28	GUHS-2.5x11-28-3	3	285	569
	GUHS-2.5x11-28-4	4	227	453
	GUHS-2.5x11-28-6	6	181	349
	GUHS-2.5x11-28-8	8	146	291
29	GUHS-2.5x11-29-3	3	291	582
	GUHS-2.5x11-29-4	4	232	463
	GUHS-2.5x11-29-6	6	184	356
	GUHS-2.5x11-29-8	8	149	297
30	GUHS-2.5x11-30-3	3	298	595
	GUHS-2.5x11-30-4	4	237	473
	GUHS-2.5x11-30-6	6	188	363
	GUHS-2.5x11-30-8	8	151	302
31	GUHS-2.5x11-31-3	3	306	612
	GUHS-2.5x11-31-4	4	243	486
	GUHS-2.5x11-31-6	6	193	372
	GUHS-2.5x11-31-8	8	155	309
32	GUHS-2.5x11-32-3	3	315	629
	GUHS-2.5x11-32-4	4	250	499
	GUHS-2.5x11-32-6	6	198	382
	GUHS-2.5x11-32-8	8	159	317
33	GUHS-2.5x11-33-3	3	323	646
	GUHS-2.5x11-33-4	4	256	512
	GUHS-2.5x11-33-6	6	202	391
	GUHS-2.5x11-33-8	8	162	317
34	GUHS-2.5x11-34-3	3	329	658
	GUHS-2.5x11-34-4	4	261	521
	GUHS-2.5x11-34-6	6	206	398
	GUHS-2.5x11-34-8	8	165	330
35	GUHS-2.5x11-35-3	3	338	675
	GUHS-2.5x11-35-4	4	267	534
	GUHS-2.5x11-35-6	6	211	407
	GUHS-2.5x11-35-8	8	169	337
36	GUHS-2.5x11-36-3	3	346	692
	GUHS-2.5x11-36-4	4	274	547
	GUHS-2.5x11-36-6	6	216	417
	GUHS-2.5x11-36-8	8	172	344
37	GUHS-2.5x11-37-3	3	355	709
	GUHS-2.5x11-37-4	4	280	560
	GUHS-2.5x11-37-6	6	221	426
	GUHS-2.5x11-37-8	8	176	351
38	GUHS-2.5x11-38-3	3	361	722
	GUHS-2.5x11-38-4	4	285	570
	GUHS-2.5x11-38-6	6	221	433
	GUHS-2.5x11-38-8	8	179	357
39	GUHS-2.5x11-39-3	3	370	739
	GUHS-2.5x11-39-4	4	292	583
	GUHS-2.5x11-39-6	6	229	442
	GUHS-2.5x11-39-8	8	182	364

Standard Specifications:

Frame - 4 in. deep x 1 1/2 in. flange x 7 ga. painted steel channel with bolt-in cross members for rollers high; welded cross members for rollers low.

Between Frame Widths - 13 through 39 in full one inch increments (larger widths available).

End Couplers - Bolt-on type for bolting sections together.

Lengths - 5 ft. and 10 ft. straight sections.

Rollers - 2 1/2 in. dia. x 11 ga. steel tubing. Grease packed plain ball bearings both ends. Labyrinth shielded bearings optional.

Axles - 11/16 spring retained hex axle spaced on 3 in., 4 in., 6 in., 8 in., 9 in. or 12 in. centers.

Gravity Roller Conveyor

2 9/16 in. dia. x .180 Wall Rollers

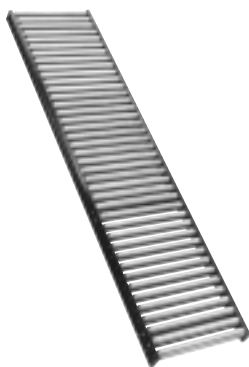

2 9/16 in. dia. Gravity Roller Conveyor is used in permanent installations. It provides an economical means of carrying medium to heavy weight packages.

- 27 Between Frame Widths
- 6 Roller Centers
- Painted Steel Frames
- Bolt-in Cross Members

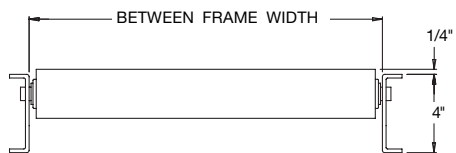

ROLLERS HIGH

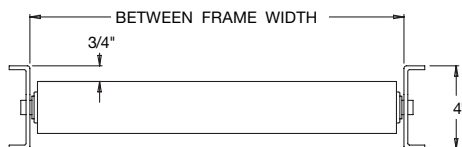

ROLLERS LOW
(Optional)

LOAD CAPACITY CHART		
Support Centers	Frame Capacity	Roller Capacity
	Max. Uniformly Distributed Load	Max. Load Per Roller
5'	5200	650
10'	2100	

Between Frame Width	Model No. 2 9/16" Rollers	Roller Centers (inches)	Weights (Lbs.)	
			5'	10'
13	GUHS-2.6x7-13-3	3	203	405
	GUHS-2.6x7-13-4	4	164	327
	GUHS-2.6x7-13-6	6	133	257
	GUHS-2.6x7-13-8	8	109	218
14	GUHS-2.6x7-14-3	3	211	422
	GUHS-2.6x7-14-4	4	170	340
	GUHS-2.6x7-14-6	6	137	266
	GUHS-2.6x7-14-8	8	113	225
15	GUHS-2.6x7-15-3	3	224	447
	GUHS-2.6x7-15-4	4	180	359
	GUHS-2.6x7-15-6	6	144	279
	GUHS-2.6x7-15-8	8	118	235
16	GUHS-2.6x7-16-3	3	232	463
	GUHS-2.6x7-16-4	4	186	371
	GUHS-2.6x7-16-6	6	149	289
	GUHS-2.6x7-16-8	8	122	243
17	GUHS-2.6x7-17-3	3	244	488
	GUHS-2.6x7-17-4	4	195	390
	GUHS-2.6x7-17-6	6	156	302
	GUHS-2.6x7-17-8	8	127	253
18	GUHS-2.6x7-18-3	3	255	509
	GUHS-2.6x7-18-4	4	203	406
	GUHS-2.6x7-18-6	6	162	313
	GUHS-2.6x7-18-8	8	131	262
19	GUHS-2.6x7-19-3	3	263	526
	GUHS-2.6x7-19-4	4	210	419
	GUHS-2.6x7-19-6	6	167	323
	GUHS-2.6x7-19-8	8	135	269
20	GUHS-2.6x7-20-3	3	274	547
	GUHS-2.6x7-20-4	4	218	435
	GUHS-2.6x7-20-6	6	173	334
	GUHS-2.6x7-20-8	8	139	278
21	GUHS-2.6x7-21-3	3	284	568
	GUHS-2.6x7-21-4	4	226	451
	GUHS-2.6x7-21-6	6	179	345
	GUHS-2.6x7-21-8	8	144	287
22	GUHS-2.6x7-22-3	3	294	588
	GUHS-2.6x7-22-4	4	233	466
	GUHS-2.6x7-22-6	6	185	357
	GUHS-2.6x7-22-8	8	148	296
23	GUHS-2.6x7-23-3	3	305	609
	GUHS-2.6x7-23-4	4	241	482
	GUHS-2.6x7-23-6	6	191	368
	GUHS-2.6x7-23-8	8	153	304
24	GUHS-2.6x7-24-3	3	315	630
	GUHS-2.6x7-24-4	4	249	498
	GUHS-2.6x7-24-6	6	197	379
	GUHS-2.6x7-24-8	8	157	313
25	GUHS-2.6x7-25-3	3	326	651
	GUHS-2.6x7-25-4	4	257	514
	GUHS-2.6x7-25-6	6	202	391
	GUHS-2.6x7-25-8	8	161	322
26	GUHS-2.6x7-26-3	3	336	672
	GUHS-2.6x7-26-4	4	265	530
	GUHS-2.6x7-26-6	6	208	402
	GUHS-2.6x7-26-8	8	166	331

Note: Also available with 9 in. or 12 in. roller centers.

Between Frame Width	Model No. 2 9/16" Rollers	Roller Centers (inches)	Weights (Lbs.)	
			5'	10'
27	GUHS-2.6x7-27-3	3	347	693
	GUHS-2.6x7-27-4	4	273	546
	GUHS-2.6x7-27-6	6	214	413
	GUHS-2.6x7-27-8	8	170	340
28	GUHS-2.6x7-28-3	3	357	713
	GUHS-2.6x7-28-4	4	281	561
	GUHS-2.6x7-28-6	6	220	425
	GUHS-2.6x7-28-8	8	175	349
29	GUHS-2.6x7-29-3	3	367	734
	GUHS-2.6x7-29-4	4	289	577
	GUHS-2.6x7-29-6	6	226	436
	GUHS-2.6x7-29-8	8	179	357
30	GUHS-2.6x7-30-3	3	378	755
	GUHS-2.6x7-30-4	4	297	593
	GUHS-2.6x7-30-6	6	232	447
	GUHS-2.6x7-30-8	8	183	366
31	GUHS-2.6x7-31-3	3	388	776
	GUHS-2.6x7-31-4	4	305	609
	GUHS-2.6x7-31-6	6	238	459
	GUHS-2.6x7-31-8	8	188	375
32	GUHS-2.6x7-32-3	3	399	797
	GUHS-2.6x7-32-4	4	313	625
	GUHS-2.6x7-32-6	6	244	470
	GUHS-2.6x7-32-8	8	192	384
33	GUHS-2.6x7-33-3	3	409	818
	GUHS-2.6x7-33-4	4	321	641
	GUHS-2.6x7-33-6	6	250	481
	GUHS-2.6x7-33-8	8	197	393
34	GUHS-2.6x7-34-3	3	419	838
	GUHS-2.6x7-34-4	4	328	656
	GUHS-2.6x7-34-6	6	256	493
	GUHS-2.6x7-34-8	8	201	402
35	GUHS-2.6x7-35-3	3	430	859
	GUHS-2.6x7-35-4	4	336	672
	GUHS-2.6x7-35-6	6	262	504
	GUHS-2.6x7-35-8	8	206	410
36	GUHS-2.6x7-36-3	3	440	880
	GUHS-2.6x7-36-4	4	344	688
	GUHS-2.6x7-36-6	6	268	515
	GUHS-2.6x7-36-8	8	210	419
37	GUHS-2.6x7-37-3	3	451	901
	GUHS-2.6x7-37-4	4	352	704
	GUHS-2.6x7-37-6	6	273	527
	GUHS-2.6x7-37-8	8	214	428
38	GUHS-2.6x7-38-3	3	461	922
	GUHS-2.6x7-38-4	4	360	720
	GUHS-2.6x7-38-6	6	279	538
	GUHS-2.6x7-38-8	8	219	437
39	GUHS-2.6x7-39-3	3	472	943
	GUHS-2.6x7-39-4	4	368	736
	GUHS-2.6x7-39-6	6	285	549
	GUHS-2.6x7-39-8	8	223	446

Standard Specifications:

Frame - 4 in. deep x 1 1/2 in. flange x 7 ga. painted steel channel with bolt-in cross members for rollers high, welded cross members for rollers low.

Between Frame Widths - 13 through 39 in full one inch increments (larger widths available).

End Couplers - Bolt-on type for bolting sections together.

Lengths - 5 ft. and 10 ft. straight sections.

Rollers - 2 9/16 in. dia. x .180 wall steel tubing. Grease packed plain ball bearings. Labyrinth shielded bearings optional.

Axles - 11/16 spring retained hex axle spaced on 3 in., 4 in., 6 in., 8 in., 9 in. or 12 in. centers.

Gravity Roller Conveyor (Built to Your Specifications)

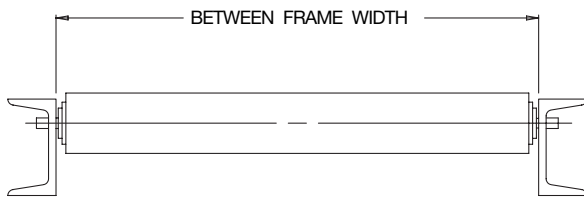
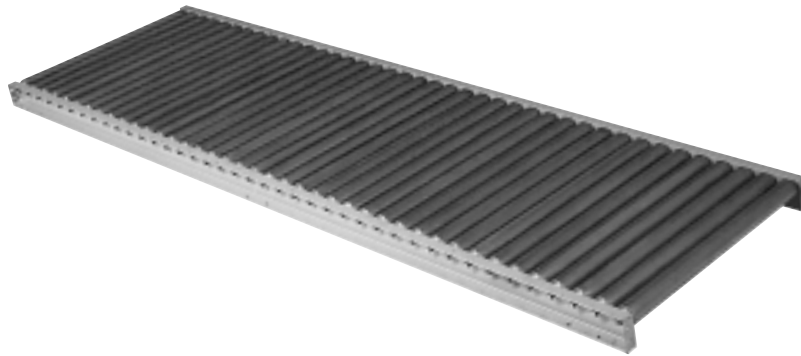

STYLE	A	B	C
1			
2			
3			
4			

Side Frame	Frame Capacity (lbs.)	
	5' Supp.	10' Supp.
L 2 x 1 1/2 x 3/16	850	200
C 2 1/2 x 1 x 12 ga.	1300	350
L 2 1/2 x 2 x 3/16	1700	420
L 2 1/2 x 2 x 1/4	2000	550
C 3 x 4.1#	5800	1400
L 3 x 2 x 3/16	2100	580
L 3 x 2 x 1/4	2800	960
C 3 1/2 x 1 1/2 x 10 ga.	3300	1200
C 4 x 5.4#	10000	3300
L 4 x 3 x 5/16	6500	2900
C 5 x 1 1/2 x 7 ga.	6800	3400
C 5 x 6.7#	16000	6600
L 5 x 3 1/12 x 5/16	10000	5000
C 5 1/2 x 1 1/2 x 10 ga.	5500	2400
C 6 x 8.2#	22000	11000
C 8 x 11.5#	43000	21000
C 10 x 15.3#	71000	35000
C 10 x 20.0#	83000	41000
C 12 x 20.7#	113000	56000
C 15 x 40.0#	180000	92000

Standard Information

- Wide variety of side frames built to specified width and length requirements. Additional frames available.
- Welded rigid construction
- Gravity rollers from 1 in. through 8 in. dia. (See roller selection chart.)
- Roller spacing: 1 1/2 in., 3 in., 4 in., 6 in. typical. Other spacing available.

Other Options

- Curves with Straight or Tapered Rollers
- Spurs
- Manual or Power Operated Stops
- Friction Brakes
- "H" Type Leg Supports

Gravity Rollers

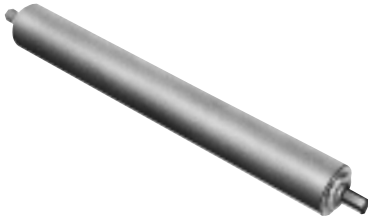

Tube Diameter x Wall Thickness	Axle Size	Bearing Options					Axle Retention		Between Frame Ranges (inches) Spring/Pin	Roller Capacity at Optimum B.F.*
		Non-Replaceable	Plain	Shielded	Sealed	Regreaseable	Spring	Pin or Ring		
1" O.D. x 16 ga.	5/16" Hex	■	■				■		6-27/Opt.	60 lbs.
1 3/8" O.D. x 18 ga.	1/4" Hex	■					■		7-39/Opt.	120 lbs.
1 3/8" O.D. x 16 ga.	5/16" Rd.		■				■		8-39/Opt.	94/120 lbs.
1 3/8" O.D. x 3/16" wall	5/16" Hex			■			■		6-39/Opt.	150 lbs.
1 3/8" O.D. x 3/16" wall	7/16" Hex	■	■				■	■	7-39/Opt.	150 lbs.
1.9" O.D. x 16 ga.	7/16" Hex	■	■		■		■	■	7-53/7-53	260/290 lbs.
1.9" O.D. x 13 ga.	7/16" Hex						■	■	7-56/3-63	260 lbs.
1.9" O.D. x .145 wall	7/16" Hex			■			■	■	7-56/3-63	300/585 lbs.
2" O.D. x 16 ga.	7/16" Hex		■		■		■	■	7-53/7-53	290 lbs.
2 1/4" O.D. x 9 ga.	5/8" Hex		■				■	■	8-57/3-75	450 lbs.
2 1/2" O.D. x 13 ga.	7/16" Hex		■		■		■	■	7-56/3-63	290 lbs.
2 1/2" O.D. x 11 ga.	7/16" Hex		■		■		■	■	7-56/3-63	290 lbs.
2 1/2" O.D. x 11 ga.	5/8" Hex		■		■	■	■	■	7-56/3-75	580 lbs.
2 1/2" O.D. x 11 ga.	11/16" Hex		■	■	■	■	■	■	7-56/3-75	580/650/700 lbs.
2 9/16" O.D. x .180 wall	11/16" Hex		■	■	■	■	■	■	7-56/3-75	580/650/2226 lbs.
3 1/2" O.D. x .180 wall	11/16" Hex		■		■	■	■	■	7-56/3-75	580 lbs.
3 1/2" O.D. x .300 wall	1 1/16" Hex		■	■	■	■		■	N.A./3-99	1040/4130 lbs.
3 1/2" O.D. x .300 wall	1 7/16" Rd.				■			■	N.A./4-120	6172 lbs.
4" O.D. x 1/2" wall	1 7/16" Rd.				■			■	N.A./4-120	6172 lbs.
5" O.D. x 3/4" wall	1 7/16" Rd.				■			■	N.A./4-120	6172 lbs.
5" O.D. x 3/4" wall	1 11/16" Rd.				■			■	N.A./4-120	7836 lbs.
5 9/16" O.D. x 3/4" wall	1 11/16" Rd.				■			■	N.A./4-120	7836 lbs.
6 1/2" O.D. x 7/8" wall	2 7/16" Rd.				■			■	N.A./4-120	12,550 lbs.
7 5/8" O.D. x 7/8" wall	1 11/16" Rd.				■			■	N.A./4-120	7836 lbs.
7 5/8" O.D. x 7/8" wall	2 15/16" Rd.				■			■	N.A./4-120	15,878 lbs.
8" O.D. x 1" wall	2 15/16" Rd.				■			■	N.A./4-120	15,878 lbs.

*Multiple roller capacities indicate multiple bearing options.

Standard Information

- Roller diameters from 1 in. through 8 in.
- Pin or spring retained axle
- Various bearing options
- Quick delivery

Note: The above list is an overview of general sizes available. For a complete size listing and more detailed roller information, see our "Roller and Bearing Section".

Other Options

- Tapered Rollers
- Heat-Treated Rollers
- Urethane Coated Rollers
- Rollers with Plastic, Nylon, or Wood Bearings
- Aluminum, Galvanized Steel, Stainless Steel or P.V.C. Rollers

Flow Rail

<p>STYLE 1</p>	<p>STYLE 4</p>																																																					
<p>STYLE 2</p>	<p>STYLE 5</p>																																																					
<p>STYLE 3</p>	<p>LOAD CAPACITY CHART</p> <table border="1"> <thead> <tr> <th rowspan="2">Support Centers</th> <th colspan="5">Maximum Load Per Foot</th> </tr> <tr> <th>Style 1</th> <th>Style 2</th> <th>Style 3</th> <th>Style 4</th> <th>Style 5</th> </tr> </thead> <tbody> <tr> <td>3'</td> <td>179</td> <td>200*</td> <td>200*</td> <td>400</td> <td>200</td> </tr> <tr> <td>4'</td> <td>100</td> <td>168</td> <td>200*</td> <td>278</td> <td>200</td> </tr> <tr> <td>5'</td> <td>62</td> <td>107</td> <td>200*</td> <td>142</td> <td>144</td> </tr> <tr> <td>6'</td> <td>36</td> <td>74</td> <td>166</td> <td>82</td> <td>83</td> </tr> <tr> <td>7'</td> <td>22</td> <td>54</td> <td>104</td> <td>51</td> <td>52</td> </tr> <tr> <td>8'</td> <td>15</td> <td>42</td> <td>70</td> <td>34</td> <td>35</td> </tr> <tr> <td>10'</td> <td>7</td> <td>23</td> <td>35</td> <td>17</td> <td>18</td> </tr> </tbody> </table> <p>* Wheel capacity is limiting factor.</p>	Support Centers	Maximum Load Per Foot					Style 1	Style 2	Style 3	Style 4	Style 5	3'	179	200*	200*	400	200	4'	100	168	200*	278	200	5'	62	107	200*	142	144	6'	36	74	166	82	83	7'	22	54	104	51	52	8'	15	42	70	34	35	10'	7	23	35	17	18
Support Centers	Maximum Load Per Foot																																																					
	Style 1	Style 2	Style 3	Style 4	Style 5																																																	
3'	179	200*	200*	400	200																																																	
4'	100	168	200*	278	200																																																	
5'	62	107	200*	142	144																																																	
6'	36	74	166	82	83																																																	
7'	22	54	104	51	52																																																	
8'	15	42	70	34	35																																																	
10'	7	23	35	17	18																																																	

- 12 ga. galvanized steel frames
- 1 15/16 in. dia. wheels
- Wheel capacity = 50 lbs.

- Wheels are on 3 in. centers
- Style 4 is also available with wheels staggered

Pallet Rail

<p>STYLE 1</p>	<p>STYLE 3</p>
<p>STYLE 2</p>	<p>STYLE 4</p>

- 7 ga. painted frames
- 2 1/4 in. dia. wheels
- Wheel capacity = 290 lbs.

- Wheels available on 3 in., 6 in. or 12 in. centers
- Frame capacity (uniformly distributed load) 300 lbs./ft. with supports on 5 ft. centers

TRIPOD LEG SUPPORT

- For skatewheel or 1 3/8 in. dia. roller conveyor.

	Top of Leg
A D J U S T M E N T S	11"-17"
	17"-29"
	23"-39"
	29"-51"
	39"-71"

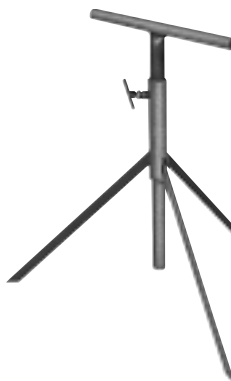

"H" TYPE LEG SUPPORT (Bolt Together Construction)

- For skatewheel, 1 3/8 in., 1.9 in., 2.5 in. or 2.6 in. dia. roller conveyors.
- Light duty and medium duty bolt together leg supports are constructed of 3 in. x 12 ga. formed channel.
- Heavy duty bolt together leg supports are constructed of 3 in. x 7 ga. formed channel.



	1.9" Roller Conveyor Top of Leg	Skatewheel, 1 3/8", 2.5" & 2.6" Roller Conveyor Top of Leg
A D J U S T M E N T S	6" - 8"	-----
	8" - 10"	-----
	10" - 12 1/4"	-----
	12 1/4" - 16 1/4"	12 1/4" - 16 1/4"
	14 1/4" - 20 1/4"	14 1/4" - 20 1/4"
	18 1/4" - 24 1/4"	18 1/4" - 24 1/4"
	22 1/4" - 28 1/4"	22 1/4" - 28 1/4"
	26 1/4" - 32 1/4"	26 1/4" - 32 1/4"
	30 1/4" - 42 1/4"	30 1/4" - 42 1/4"
	38 1/4" - 50 1/4"	38 1/4" - 50 1/4"
	46 1/4" - 58 1/4"	46 1/4" - 58 1/4"
	54 1/4" - 66 1/4"	54 1/4" - 66 1/4"
62 1/4" - 74 1/4"	62 1/4" - 74 1/4"	
70 1/4" - 82 1/4"	70 1/4" - 82 1/4"	



"H" TYPE LEG SUPPORT (Welded Construction)

- Selection of 3 in., 4 in., 5 in. or 6 in. structural channel supports dependent upon load requirements.
- Optional knee braces
- Casters available with 4 in. or 6 in. wheels

