

SNYDER

Equipment, Inc.

Storing, Rolling, Lifting since 1947

2946 LARIMER ST.
DENVER, CO 80205
303-295-1100/800-373-7693
FAX 303-295-2464
www.snyderequipment.com



ULTRA SPACE SAVER

- *Maximum bike parking capacity*
- *User-friendly, vertical storage*
- *U-lock compatible with nearly any bike*

The all-new Ultra Space Saver builds on a great initial design. The Ultra Space Saver is now more user-friendly by allowing easier access to bikes. It also provides easy and ample space for U-lock security on nearly any bike, including bikes with fenders. Thanks to design enhancements, the Ultra Space Saver double-sided parks more than double the capacity of a standard bike rack.

Like the original design, the Ultra Space Saver is an easy to install, modular system. It can be made to fit in nearly any space. Options include: wall-mount, floor-mount, and double-sided. Call Dero for a FREE custom room layout.

DERO



BIKE RACKS



ULTRA SPACE SAVER

Specifications and Space Use

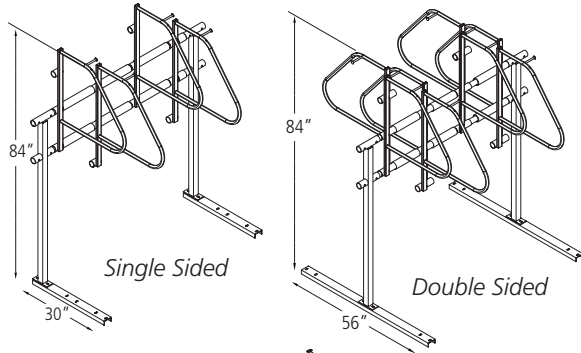

Single Sided

Double Sided

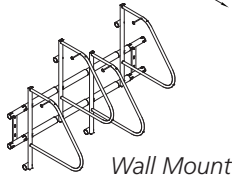

Wall Mount

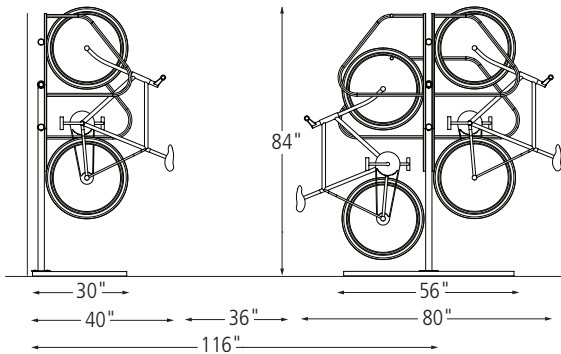

Product

Dero Ultra Space Saver
As manufactured by Dero Bike Racks

Capacity

Modular construction
1 Bike per arm

Materials



Hanger is 1" diameter tube with 1/2" steel rod and retaining disk at each end.
Upright is 2" square tube.

Finishes



Black powder coat
Cross bars: hot dipped galvanized
Hanger rods: rubber coated
Spacers: plastic

Installation Methods



Floor mounted Ultra Space Savers have steel channel feet (30" for single sided and 56" for double sided units) which must be anchored to the floor. A **wall mounted** unit which contains special brackets is also available.

Space Use and Setbacks



See diagram at left

Estimating Your Bike Capacity

Estimating the maximum number of bikes you can park using a Ultra Space Saver in a typical rectangular space is usually fairly straight forward.

The Ultra Space Saver parks one bike every 16" with a typical bike extending out 40" from the wall. Imagine a 16"x40" block of floor space as representing each bike that can be parked. Arrange the blocks in rows, leaving a 36" aisle between rows.

If you have a large space, you may be able to fit in double rows of Ultra Space Savers. In this case you could fit 2 bikes in a 16"x80" space.

Let us Help! As a free service, Dero will provide a complete CAD layout of your space. Just send us the dimensions of your room, being sure to note the location of doors, columns, etc. and let us maximize your bike storage capacity.

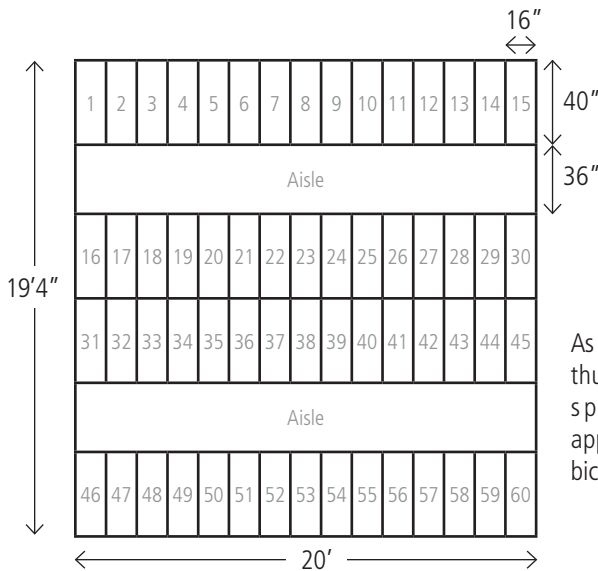

As a general rule of thumb, a 20'x20' space can fit approximately 60 bicycles.



The Ultra Space Saver has several steps for installation. Note that the single and double sided setups and parts are different. Make sure you follow the instructions according to the model you ordered.

Recommended Base Materials:

Solid concrete is the best base material for installation. Make sure nothing is underneath the base material that could be damaged by drilling (i.e. post-tension cable). Use the 3.75" wedge anchors that are included to install the rack into the concrete (wall anchors are 3").

Installation:

Sort out the parts to the rack and identify each of them accordingly. The 1" carriage bolts are for assembly of the rack and the 3.75" wedge anchors are for mounting the rack to the floor.

Reading your Dero designed layout

Ultra Space Savers come in varying configurations, making it **very important** that you carefully follow the layout provided by Dero when installing the racks. If you do not follow the diagram, you may well end up short of parts. The length of each Ultra Space Saver unit is indicated by a number ranging from B2-B7 in the layout. This number corresponds to the length of crossbeams to be installed. In the example provided below the Ultra Space Saver is to be installed starting with two B4 units, which have 45" crossbeams, followed by a B5, which has 77" crossbeams.

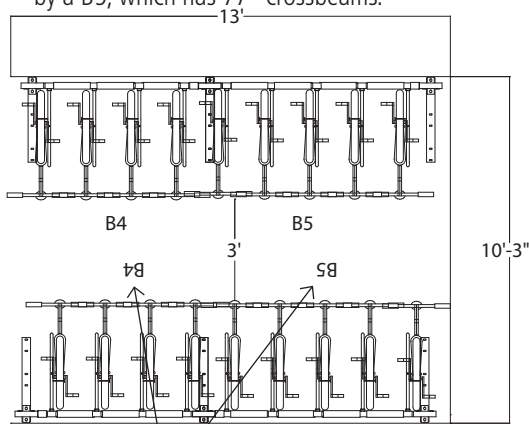

These numbers indicate the number of arms between brackets for each Ultra Space Saver unit to be installed.

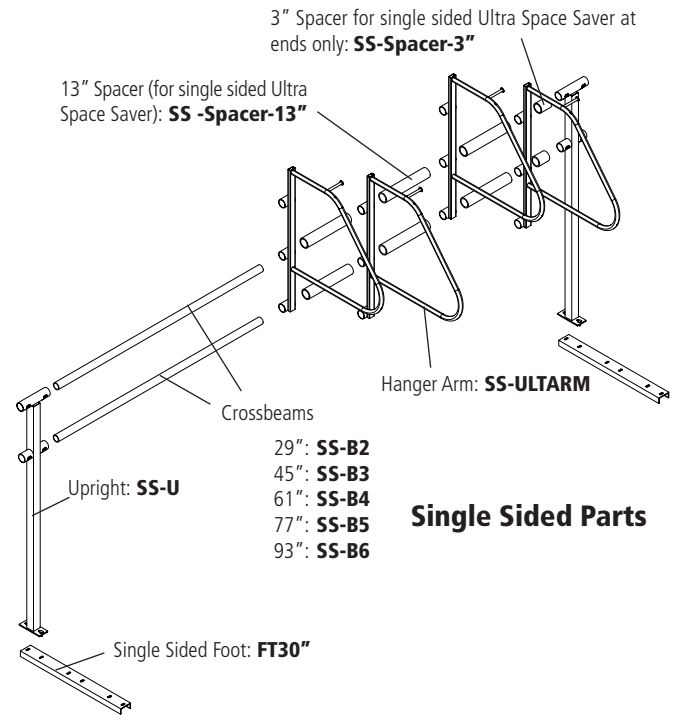

Single Sided Parts

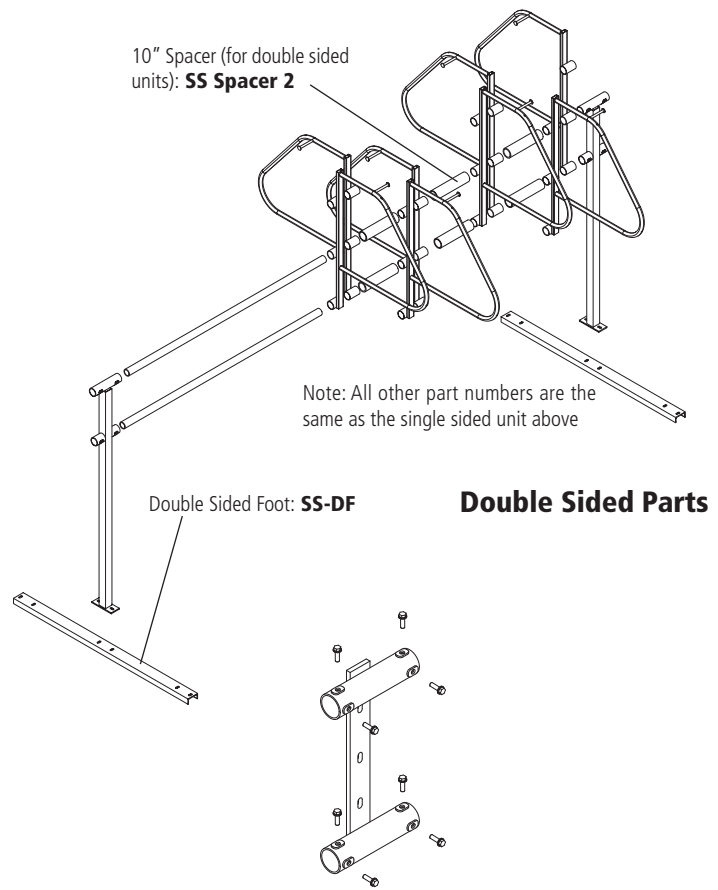

Double Sided Parts

Wall Mounting Bracket

(Wall Mounted Only) - SS-W



Tools Needed for Installation

- 9/16" Wrench/Socket
- 3/8" or 1/2" Masonry Drill Bit (Depending on anchor type)
- Tape Measure
- Drill (Hammer drill recommended)
- Hammer
- Level
- Marker or pencil



Install Steps



Before installing make sure the wall is strong enough to accommodate the rack fully loaded with bikes. Steel stud walls are not suitable for installation

- 1** Lay out parts on the floor where unit is to be installed and be sure you have all necessary parts.
- 2** On galvanized cross beams, Place a mark three inches from each end. This mark will show you how far to slide the cross beam into the wall bracket.
- 3** Place first wall bracket on wall where you want to install the bike rack. Bottom of bracket should be at least 50" from ground. Mark holes for drilling.
- 4** Drill Holes into wall, put the wall bracket back up and insert wall anchors through holes in bracket and set the anchors. For setting the anchors and diameter and depth of holes, follow instructions sent with the anchors. Make sure bracket is level.
- 5** Thread 3/8" by 3/4" tightening bolts into holes in bracket. Insert crossbeams into bracket. Slide on arms and spacers, make sure arms are staggered. At end of last arm place 3" spacers and install end bracket, making sure cross beams are level.
- 6** If installing more than one set of Ultra Space Saver arms, continue from last installed wall bracket and repeat steps 3-5 above.

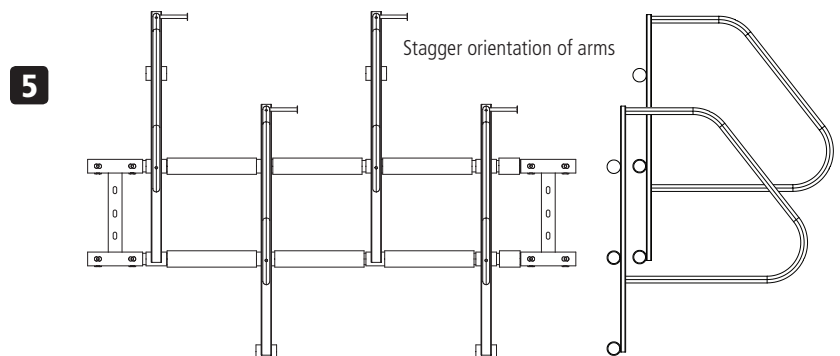
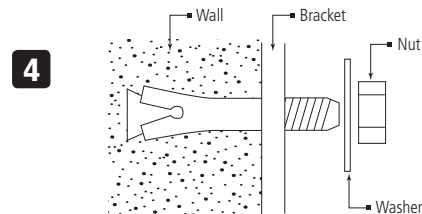
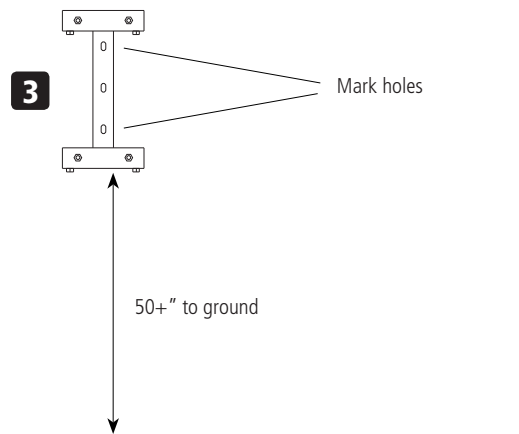



Tools Needed for Installation

- 9/16" Wrench/Socket
- 3/8" Masonry Drill Bit
- Tape Measure
- Drill (Hammer drill recommended)
- Hammer

Install Steps

- 1** Measure out space. Attach feet to uprights with carriage provided.
- 2** Lay assembled uprights with crossbeams attached on their side so crossbeams are facing up. Slide first hanger arm on. Then slide the plastic spacers on.
- 3** Slide next arm on but make sure to flip each arm so that the hanger rod is at a different level from its neighboring arms. For double sided model slide arms on opposite each other. Repeat until the crossbeams are full. For Single-sided installs place 3" spacer at end (part# SS-Spacer-3")
- 4** Tip rack up and attach the second upright. Tighten bolts. Slide assembled rack into final location. For add-on units repeat steps.
- 5** Anchor rack to floor with 3.75" wedge anchors.

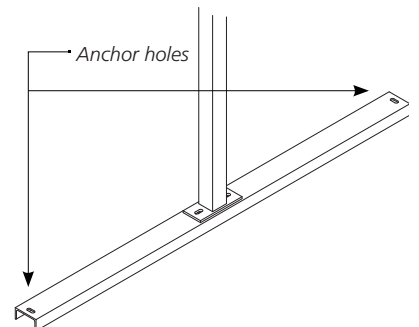
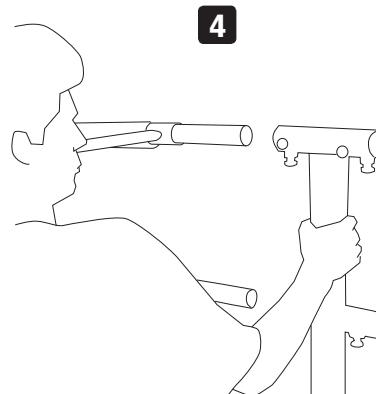
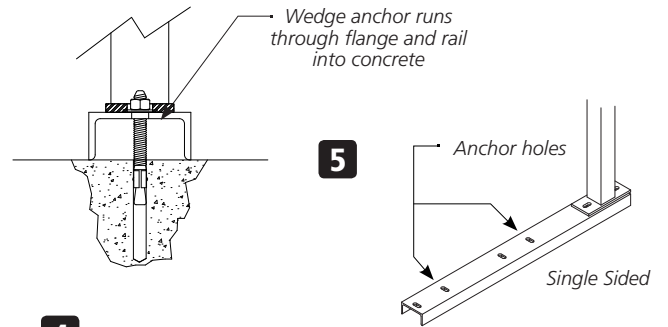
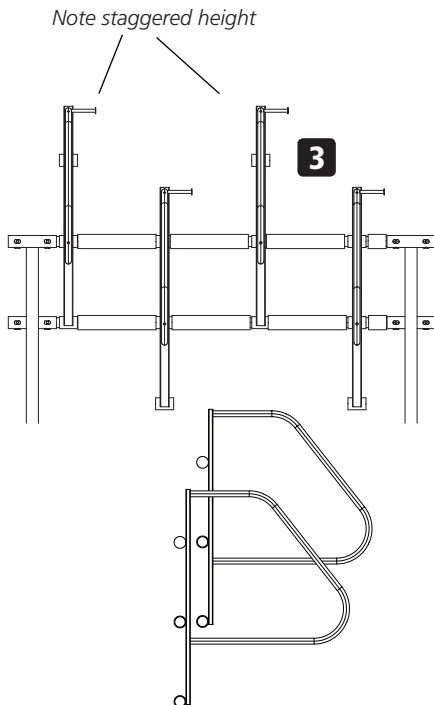
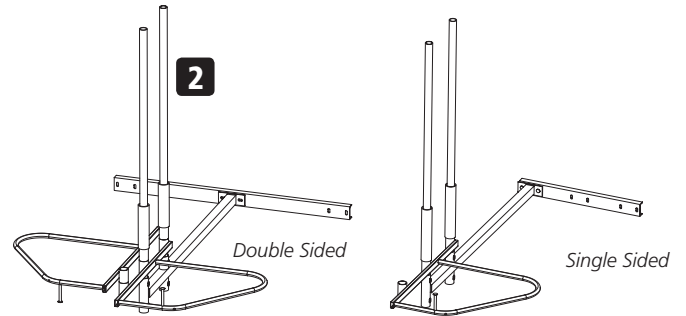
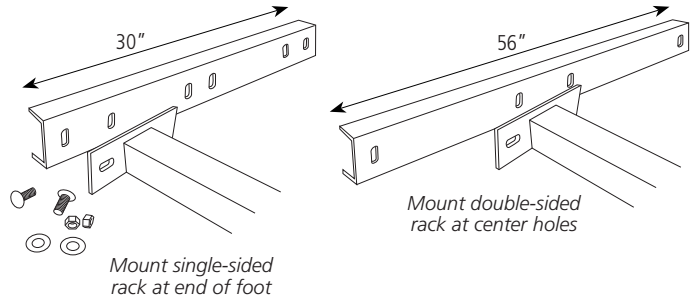



You may find it necessary to field fit a Ultra Space Saver. The following instructions describe this process.

Tools Needed for Installation

- Saw for cutting PVC pipe (such as a SkilSaw)
- Saw for cutting metal pipe
- Tape Measure

Instructions

- The Space Saver crossbeams come in increments of 16". Cut your crossbeams down in increments of 16" to get the appropriate fit. For example. If you ordered a length of 12 Space Savers (128" long) but you only have 120" of space as shown in this diagram, but the crossbeams down 16". This will eliminate one arm from the system. If you only have 108" of available space, you will need to cut 32" from your system and will lose two arms.

If the system you ordered barely doesn't fit (less than 3" too large), you CAN eliminate the 3" end spacers and cut down the crossbeams by 3". You will NOT lose an arm by doing this.

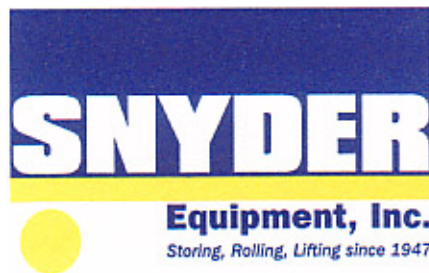
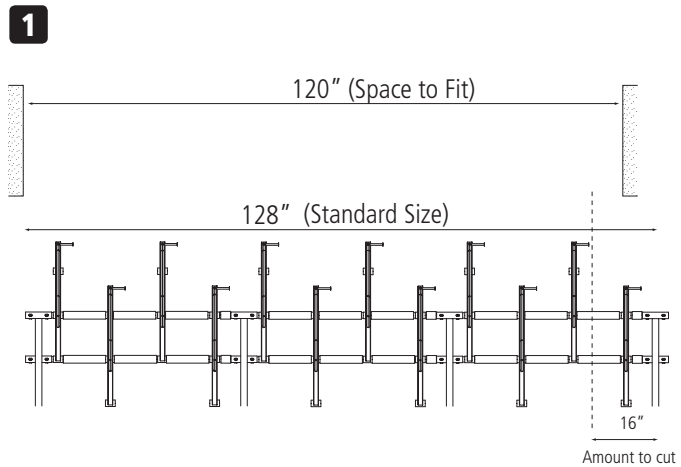

2946 LARIMER ST.
DENVER, CO 80205
303-295-1100/800-373-7693
FAX 303-295-2464
www.snyderequipment.com